



Explorer 538/538i

Chartplotter





Installation and Operation Manual

NORTHSTAR

www.northstarnav.com

IMPORTANT SAFETY INFORMATION

Please read carefully before installation and use.

	This is the safety alert symbol. It is used to alert you to potential personal injury hazards, Obey all safety messages that follow this symbol to avoid possible injury or death.
	WARNING indicates a potentially hazardous situation which, if not avoided, could result in death or serious injury
	CAUTION indicates a potentially hazardous situation which, if not avoided, could result in minor or moderate injury.
	CAUTION used without the safety alert symbol indicates a potentially hazardous situation which, if not avoided, may result in property damage.

DISCLAIMER: It is the owner's sole responsibility to install and use the instrument and transducers in a manner that will not cause accidents, personal injury or property damage. The user of this product is solely responsible for observing safe boating practices.

BRUNSWICK NEW TECHNOLOGIES INC. AND ITS SUBSIDIARIES AND AFFILIATES DISCLAIM ALL LIABILITY FOR ANY USE OF THIS PRODUCT IN A WAY THAT MAY CAUSE ACCIDENTS, DAMAGE OR THAT MAY VIOLATE THE LAW.

Governing Language: This statement, any instruction manuals, user guides and other information relating to the product (Documentation) may be translated to, or

has been translated from, another language (Translation). In the event of any conflict between any Translation of the Documentation, the English language version of the Documentation will be the official version of the Documentation.

This manual represents the Explorer 538/538i as at the time of printing. Brunswick New Technologies Inc. and its subsidiaries and affiliates reserve the right to make changes to specifications without notice.

Copyright © 2006 Brunswick New Technologies Inc. Northstar™ is a registered trademark of Brunswick New Technologies Inc

FCC Statement

Note: This equipment has been tested and found to comply with the limits for a Class B digital device, pursuant to Part 15 of the FCC Rules. These limits are designed to provide reasonable protection against harmful interference in a normal installation. This equipment generates, uses and can radiate radio frequency energy and, if not installed and used in accordance with the instructions, may cause harmful interference to radio communications. However, there is no guarantee that interference will not occur in a particular installation. If this equipment does cause harmful interference to radio or television reception, which can be determined by turning the equipment off and on, the user is encouraged to try to correct the interference by one or more of the following measures:

- Reorient or relocate the receiving antenna.
- Increase the separation between the equipment and receiver.
- Connect the equipment into an output on a circuit different from that to which the receiver is connected.
- Consult the dealer or an experienced technician for help.
- A shielded cable must be used when connecting a peripheral to the serial ports.

Important

It is your sole responsibility to install and use Northstar's instrument and GPS antenna in a manner that will not cause accidents, personal injury or property damage. Always observe safe boating practices.

The choice, location, angle and installation of the instrument & GPS antenna are critical to performance of the system as intended. Follow instructions in this manual carefully. If in doubt, consult your Northstar dealer.

Ensure that any holes cut are in a safe position and will not weaken the boat's structure. If in doubt, consult a qualified boat builder.

Global Position System: The global Position System (GPS) is operated by the U.S. Government which is solely responsible for its operation, accuracy and maintenance. The GPS is subject to changes which could affect the accuracy and performance of all GPS equipment anywhere in the world. To reduce the risk of misusing or misinterpreting the Explorer, you must read and understand all aspects of this Installation & Operation Manual. We also recommend that you practice all operations using the built-in simulator before using the Explorer.

Electronic Chart: The electronic chart used by Explorer is an aid to navigation designed to supplement, not replace official government charts. Only official government charts supplemented by notices to mariners contain the information required for safe and prudent navigation, Always supplement the electronic information provided by Explorer with other plotting sources such as observations, depth soundings, radar and hand compass bearings. Should the information not agree, the discrepancy must be resolved before proceeding any further.

Fuel Computer: Do not rely on the fuel computer as the sole source of information regarding available fuel onboard. Fuel economy can change drastically depending on boat loading and sea conditions. Fuel Computer information should be supplemented by visual or other checks of the fuel load. This is necessary due to possible operator errors such as forgetting to reset the fuel used when filling the tank, running the engine with the Fuel Computer not switched on, or on other operator actions that may render the device inaccurate. Always carry adequate fuel onboard for the intended trip, plus a reserve to allow for unforeseen circumstances.

Failure to adhere to these warnings may lead to death, serious injury or property damage. Northstar disclaims all liability for installation or use of this product that causes or contributes to death, injury or property damage or that violates any law.

As Northstar is continuously improving this product we retain the right to make changes to the product at any time which may not be reflected in this version of the manual. Please contact your nearest Northstar office if you require any further assistance.

Industry Canada

Operation is subject to the following two conditions: (1) this device may not cause interference, and (2) this device must accept any interference, including interference that may cause undesired operation of the device.

The Explorer is set up with default units of feet, °F (Fahrenheit), US gallons and knots. To change the units, see section 14-8.

Contents

Important	3
Quick reference	6
1 Introduction	7
1-1 Overview	7
1-2 Cleaning and maintenance	7
1-3 Plug-in cards	7
1-4 Removing and replacing the display unit	8
2 Basic Operation	9
2-1 Using the keys	9
2-2 Using the menus	10
2-3 Turning on and off / auto power	10
2-4 Backlight and night mode	11
2-5 Man overboard (MOB)	11
2-6 Alarms	11
2-7 Simulate mode	12
2-8 The main displays	12
3 Navigation: Chart	16
3-1 Overview of navigating	16
3-2 Chart display	18
3-3 Distance and bearing calculator	20
3-4 Projected course	21
3-5 Tracks and tracking	21
4 Navigation: Highway display	22
5 Navigation: Waypoints	22
5-1 Waypoints display	23
5-2 Managing waypoints	23
6 Navigation: Routes	25
6-1 Routes display	25
6-2 Managing routes	26
7 Satellites	28
7-1 Satellite display	29

8 Gauges display	30
9 Data display	31
10 Fuel functions and display	31
10-1 When you add or remove fuel	31
10-2 Fuel display	32
10-3 Fuel consumption curves	33
10-3-2 Managing fuel consumption curves	34
11 Tides display	35
12 User card display	36
13 About display	37
14 Setting up the Explorer 538/538i	38
14-1 Setup > System	38
14-2 Setup > Chart	40
14-3 Setup > GPS	43
14-4 Setup > Fuel	44
14-5 Setup > Track	45
14-6 Setup > Logs	46
14-7 Setup > Alarms	46
14-8 Setup > Units	47
14-9 Setup > Comms	47
14-10 Setup > Calibrate	48
14-11 Setup > Time	48
14-12 Setup > Simulate	48
15 Installation	49
15-1 Installation: What comes with the Explorer 538/538i	49
15-2 Installation: Options and Accessories	49
15-3 Installation: The display unit	51
15-4 Installation: Power/Data cable.....	52
15-5 Installation: GPS antenna	53
15-6 Installation: Northstar petrol/gasoline sensors	53
15-7 Installation: SmartCraft	54
15-8 Installation: Other NavBus instruments	54
15-9 Installation: Other NMEA instruments	55
15-10 Installation: Setup and test	55

Appendix A - Specifications.....	56
Appendix B - Troubleshooting.....	58
Appendix C - Glossary and navigation data.....	61

Quick reference

Feature	Type	See	Requires
General	How to use the keys and displays	2	
	Troubleshooting	Appendix B	
	Simulate mode	2-6	
	Glossary of special names	Appendix C	
	Specifications	Appendix A	
MOB	Man overboard key	2-4	
Navigation	Overview of how to navigate	3-1	GPS fix
	Finding the boat's position on the chart	3-2	
	Navigate to any point or to a waypoint	3-1	
	Navigate along a route	3-1	
	Projected course: An estimate of progress	3-4	
	Tracks: records of where the boat has been	3-5	
	GPS receiver status	7	
	Saving and loading data with a user card	12	User card
Chart data	Chart features (built in world chart)	3-2	
	Chart details	3-2-4 & 5	C-MAP™ chart
	Tides at a port	11	C-MAP™ chart
Alarms	Built in alarms	2-5	
	SmartCraft engine alarms	1-1	SmartCraft
Boat data	Data at top of main displays	2-7-2	
	Compass at top of main displays	2-7-3	
	Dedicated data display	9	
Fuel	Fuel computer, petrol/gasoline engine	10	Fuel sensors
	Fuel computer, SmartCraft engines	10	SmartCraft
	What to do when you add or remove fuel	10-1	

1 Introduction

1-1 Overview

The Northstar Explorer 538 is a compact, rugged, highly integrated marine chartplotter. It is easy to use and has a Color display. Complex functions can be performed with a few key presses, taking the hard work out of boating.

This manual covers:

Explorer 538

Color display, external GPS antenna.

Explorer 538i

Color display, internal GPS antenna.

The available functions, displays and setup menus depend on the optional sensors and instruments that are installed:

- Fuel functions require one or more petrol/gasoline sensors to be installed.

- SmartCraft engine functions require a SmartCraft system to be installed. For information on using SmartCraft, see the SmartCraft Gateway Installation and Operation Manual.
- The Explorer can send data to other instruments, such as an autopilot, and receive data from other instruments.

For information on installing options, see section 15-2.

This manual describes how to install and operate the Explorer 538/538i. Special terms are explained in Appendix C. For maximum benefit, please read this manual carefully before installing and using the unit. For more information on this instrument and other Northstar products, go to our website, www.northstarnav.com.

1-2 Cleaning and maintenance

The Explorer 538/538i screen is covered by a proprietary anti-reflection coating. To avoid damage, clean the screen only with a damp cloth and mild detergent when dirty or covered in sea salt. Avoid abrasive cleaners, petrol or other solvents. If a plug-in card gets dirty or wet, clean it with a damp cloth or mild detergent.

To optimize performance, avoid walking on or jamming cables and connectors.

Push the dust cover over the display when the Explorer 538/538i is turned off.

1-3 Plug-in cards

The Explorer 538/538i can use two kinds of plug-in card:

- **C-MAP™ chart cards** have chart details required for navigating in a particular region. When a chart card is plugged in, the extra details automatically appear on the Explorer 538/538i chart display.

The Explorer 538/538i can use NT, NT+ and NT-MAX cards.

- **C-MAP™ user cards** are used to store navigation data. Each user card expands the Explorer 538/538i memory and allows the data to be transferred to another Explorer 538/538i easily (see section 14).

Note: The older 5 volt user cards are not supported.

Changing the plug-in card

CAUTION

Handle plug-in cards carefully. Keep them in their protective cases when not plugged into the Explorer 538/538i.

Keep the holder in place in the Explorer 538/538i at all times to prevent moisture from entering the card compartment.

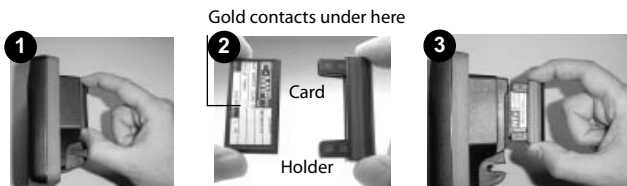

Turn the Explorer 538/538i off (see section 2-3).
Pull the card holder out of the Explorer 538/538i and pull any card out of holder.
Put the card in its case.

Push new card into holder. Ensure the gold contacts are on the outer edge and underneath (see above).
Keep the card's case.
Push card holder fully into Explorer 538/538i

1-4 Removing and replacing the display unit

If the display unit is bracket mounted then the display unit can easily be removed and replaced for security or protection.

Removing the display unit:

- 1 Turn the display unit off (see section 2-3) and put the dust cover on.
- 2 Loosen the knob on the mounting bracket and lift the unit off the bracket.
- 3 Unplug the connectors from from the display unit, turning each locking collar anticlockwise. Push the attached dust covers over the connectors.
- 4 Store the display unit in a dry clean place, such as the optional Northstar carry bag.

Replacing the display unit

- 1 Remove the dust covers from the connectors. Plug the connectors into the back of the display unit:
 - Match the connector's Color to the socket Color.



- Insert each connector and turn the locking collar clockwise until it is finger tight. Nothing will be damaged if a cable is plugged into the wrong socket by mistake.
- 2 Hold the display unit in place on the mounting bracket. Adjust the tilt of the display for best viewing, then hand tighten the knob on the mounting bracket. Remove the dust cover.

2 Basic Operation

Overview of the keys

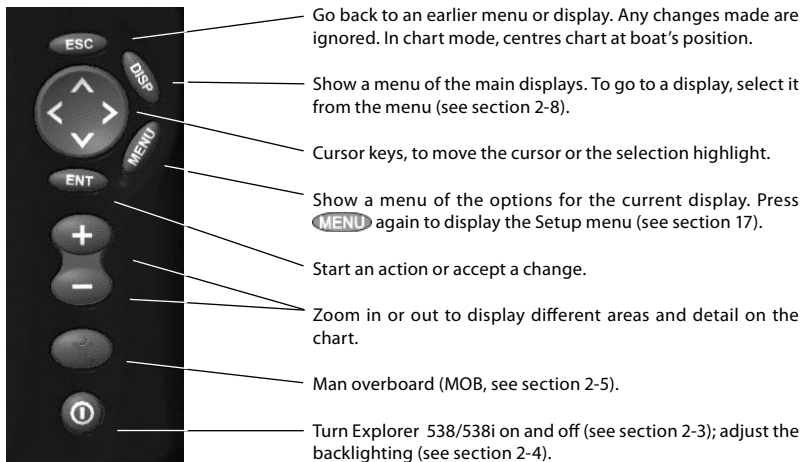

2-1 Using the keys

In this manual:

Press means to push the key for less than a second.

Hold means to hold the key down.

The internal beeper beeps when a key is pressed (to disable or enable the beep, see section 14-1).

2-2 Using the menus

Operate the Explorer 538/538i by selecting items from menus. Items can be submenus, commands or data.

Selecting a submenu

A ▶ after a menu item indicates a submenu, for example **Chart ▶**. Press ▲ or ▼ to move the highlight to the submenu, then press **ENT**.

Starting a command

Press ▲ or ▼ to move the highlight to the command, for example **Goto cursor**, then press **ENT**.

Changing data

First press ▲ or ▼ to move the highlight to the data to change, then:

a) To change a tick box

- means On or Yes
- means Off or No.

Press **ENT** or ▶ to change the tick box.

b) To select an option

- 1 Press **ENT** to display the menu of options.
- 2 Press ▲ or ▼ to move the highlight to the option you want, then press **ENT**.



c) To change a name or number:

- 1 Press **ENT** to display the name or number:

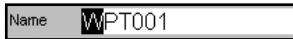

- 2 Press ◀ or ▶ to select a letter or digit to change. Press ▲ or ▼ to change the letter or digit.

Repeat this to change other letters or numbers.

- 3 Press **ENT** to accept the new value. Or press **ESC** to ignore the changes.

d) To change a slider value

Press ◀ to decrease the value or ▶ to increase the value.



2-3 Turning on and off / auto power

Turning on manually

If the Explorer 538/538i is not wired for auto power, press **⏻** to turn the unit on. If necessary, adjust the display to be easy to read (see section 2-4).

Note: If the Explorer 538/538i is not wired for auto power then the Explorer 538/538i does not record engine hours and might not record fuel consumption (see section 15-4).

Turning off manually



If the Explorer 538/538i is not wired for auto power or if the ignition switch is off, hold down **⏻** until the display turns off.

Auto power



If the Explorer 538/538i is wired for auto power (see section 15-4), then:



- The Explorer 538/538i automatically turns on when you turn the boat's ignition switch on.
- You can not turn the Explorer 538/538i off while the ignition switch is on.
- If **Auto power off** (see section 14-1) is , the Explorer 538/538i automatically turns off when you turn the boat's ignition switch off.
- If **Auto power off** (see section 14-1) is , the Explorer 538/538i stays on when you turn the boat's ignition switch off. You can now turn the Explorer 538/538i off manually.

2-4 Backlight and night mode

To go to the Backlight display, press  briefly. When you have finished, press .

Backlight

The display and keys are backlit. To change the backlight level, select **Backlight**, then press  to dim or  to brighten.

 **Tip:** Press  twice to give the brightest screen, with maximum backlight and Night mode off.

2-5 Man overboard (MOB)

The MOB feature saves the boat's position and then navigates back to this point.

WARNING

MOB will not work if the Explorer 538/538i does not have a GPS fix.

- 1 Press .
The Explorer 538/538i stores the boat's position as a waypoint called MOB.
- 2 The Explorer 538/538i changes to the chart display, with the MOB waypoint at the centre of the chart.
The chart zooms in for accurate navigation. If the chart can not show the required small scale, the Explorer 538/538i changes to plotter mode (a white display with crosshatching and no chart details, see section 14-2).
- 3 The Explorer 538/538i sets the MOB waypoint to be the destination to navigate to.

If the NMEA output (autopilot) is off (see section 14-9) use the Explorer 538/538i to manually navigate to the destination MOB waypoint (see sections 3-1-1 and 3-1-2).

 **Tip:** The MOB waypoint remains on the chart after the MOB has been cancelled. To delete the MOB waypoint, see section 5-2-5.

2-6 Alarms

When the Explorer 538/538i detects an alarm condition, it displays a warning message on the display, the internal beeper sounds and any external beepers or lights operate.

Night mode

Night mode sets the palette for all displays.

- Normal palette, for daytime
- A palette optimised for night time.

To change mode, select Night mode, then press

. To change only the chart palette, see section 17-2.

If the NMEA output (autopilot) is on, the

Explorer asks if the autopilot is active. Select:

No : Use the Explorer 538/538i to manually navigate to the destination MOB waypoint (see sections 3-1-1 and 3-1-2).

Yes : The Explorer 538/538i asks if the boat is to go to the MOB waypoint.

Select:

Yes : to immediately start navigating to the MOB waypoint.

WARNING

This might result in a sudden and dangerous turn.

No : disengage the autopilot; then use the Explorer 538/538i to manually navigate to the destination MOB waypoint (see sections 3-1-1 and 3-1-2).

To cancel MOB or set another MOB

- 1 Press  again to display a menu.
- 2 Select an option from the menu.

Press  to clear the alarm. The alarm will sound again if the alarm condition occurs again.

The Explorer 538/538i has user settable alarms plus an alarm for loss of GPS fix (see section 14-7).

2-7 Simulate mode

In Simulate mode, the Explorer 538/538i ignores data from the GPS antenna and other transducers and sensors and the Explorer 538/538i generates this data itself. Otherwise, the Explorer 538/538i functions normally.

There are two simulate modes:

- **Normal:** Allows a user to become familiar with the Explorer 538/538i off the water.
- **Demo:** Simulates a boat moving along a route and automatically displays different Explorer 538/538i functions.

To start and stop Simulate mode, and for more information, see section 14-12. In simulate mode, Simulate or Demo flashes at the bottom of the display.



WARNING

Never have Simulate mode on when the Explorer 538/538i is navigating on the water.

2-8 The main displays

To go to a display, press **DISP**, press **◀** or **▶** to select the type of display to show, press **▲** or **▼** to select the display from the list, then press **ENT**.

The available displays depend on the optional sensors and instruments that are installed (see section 1-1).

Chart menu and displays

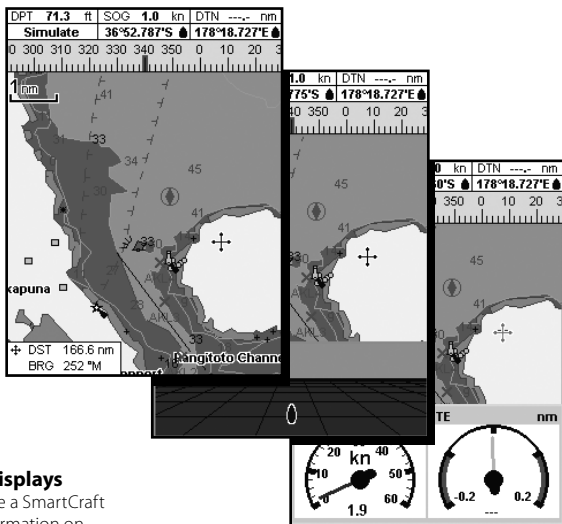
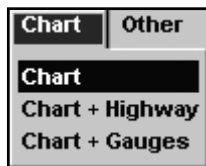

SmartCraft menu and displays

The SmartCraft displays require a SmartCraft system to be installed. For information on using SmartCraft, see the *SmartCraft Gateway Installation and Operation Manual*.

Other menu and displays

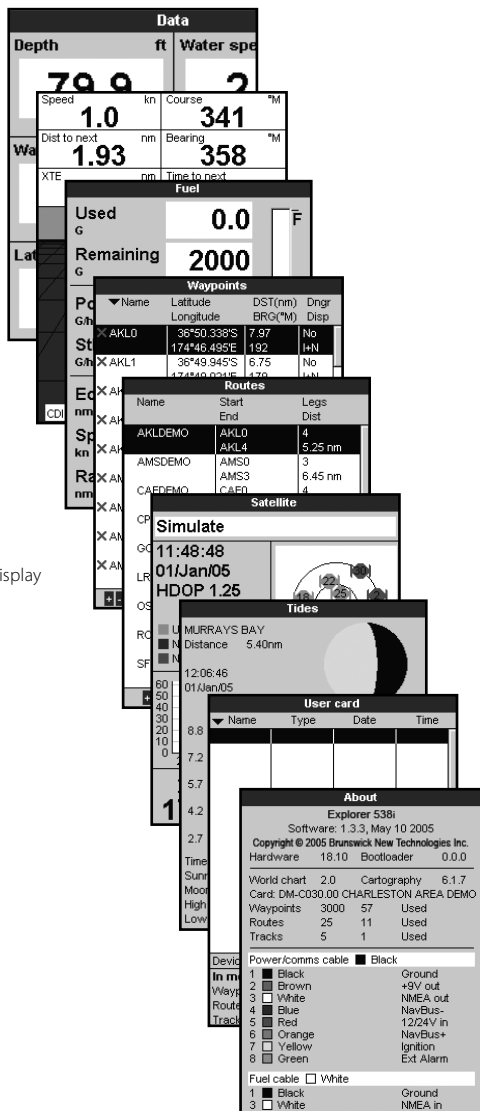

Note: Press **ESC** to go from an Other display back to your last chart display.

2-8-1 Dual displays

The Explorer 538/538i can show two displays at once, for example Chart + Gauges. One of the displays, called the active display, has a yellow border and is controlled by the user. To change the active display, press **DISP** twice (Highway cannot be the active display). For example:

- If Chart is the active display: press **MENU** to display the options for Chart; press **DISP** twice to make Gauges the active display.
- If Gauges is the active display: press **MENU** to display the options for Gauges; press **DISP** twice to make Chart the active display.

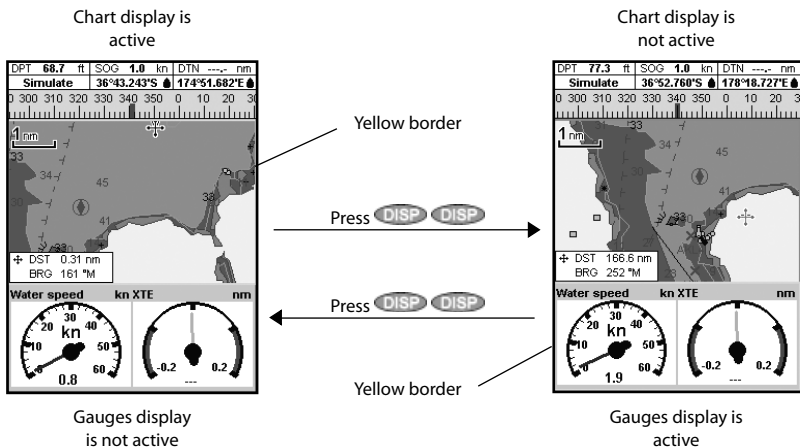

2-8-2 Data header

The chart and highway displays can show data at the top of the display.

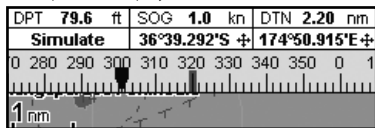

The data header for each display can be different. To change the data header for a display:

- 1 Go to the display, press **MENU** and select Data header.
- 2 To turn the data header **off** or **on**:
 - i Select Data.
 - ii Select or .
- 3 To choose the size of the numbers:
 - i Select Size.
 - ii Select Small, Medium or Large.
- 4 To change the data displayed:
 - i Select Data setup.
 - ii Change a data field:
 - a Press the cursor keys to highlight the field.
 - b Press **ENT** to display a menu of data items.
 - c Select a data item that is available on your system or select None to leave the field empty.
 - iii Repeat the above step to set the other data fields. Press **ESC**.

Tip: If less than the maximum number of lines of data are used, the data will take up less of the display area.

5 Press **ESC** to return to the display.

2-8-3 Compass

The chart and highway displays can show a compass at the top of the display.

The compass always shows the boat's course over ground (COG), a red symbol in the middle. When the boat is navigating to a point, the compass also shows bearing to the destination (BRG), a black symbol.

In this example, BRG is [300]° and COG is [320]°.

To turn the compass off or on:

- 1 Press **MENU** and select Data header.
- 2 Set Compass to or .

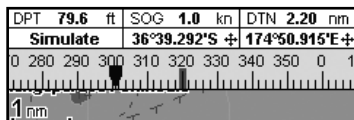

3 Navigation: Chart

The chart display shows the chart, the boat's position course and navigation data.

3-1 Overview of navigating

The Explorer 538/538i has two ways of navigating, going straight to a point or following a route.

3-1-1 Navigating to a point

When the Explorer 538/538i is navigating to a point, the chart and highway displays show navigation data:

- A The boat position 
- B The destination point marked with a circle.
- C The boat's plotted course to the destination.
- D Two CDI lines, parallel to the boat's plotted course, which indicate the maximum expected deviation from the plotted course.

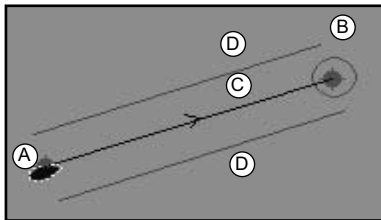

For more information, see appendix C.

If the Explorer 538/538i is connected to an autopilot, the Explorer 538/538i will send data to the autopilot to steer the boat to the destination. Start the autopilot before starting to navigate to the point.

If the Explorer 538/538i has no autopilot, steer the boat manually:

- a use the boat position and destination on the chart or highway displays
- b or use navigation data displayed on the data header (see section 2-8-2)
- c or use COG and BRG on the compass (see section 2-8-3).

Note:

- 1 If the XTE alarm is enabled, an alarm will sound if the boat deviates too much from its intended course (see section 14-7).
- 2 If the arrival radius alarm is enabled, then an alarm will sound to show that the boat has reached the destination (see section 14-7).

3-1-2 Going to a waypoint or to a point on the chart

A waypoint is a position that you can set on the Explorer 538/538i chart, for example a fishing spot or a point on a route (see section 5).

Going to a waypoint from the chart display

- 1 Go to the chart display.
- 2 Move the cursor to the waypoint: either use the cursor keys or use Find (see section 3-2-5).
- 3 Press **MENU** and select **Go to**.

Going to a waypoint from the waypoints display

- 1 Go to the waypoints display.
- 2 Press **▲** or **▼** to highlight the waypoint to go to.
- 3 Press **MENU** and select **Go to**.

Going to a point on the chart

- 1 Switch to a chart display.
- 2 Move the cursor to the destination point: either use the cursor keys or use Find (see section 3-2-5).
- 3 Press **MENU** and select **Goto** cursor.

WARNING

Make sure the course does not pass over land or dangerous waters.

Navigating

The Explorer 538/538i navigates to the point as described in section 3-1-1.

Canceling navigating

Go to a Chart display, press **MENU** and select **Cancel goto**.

 **Tip:** Before starting, create waypoints at points of interest. Create a waypoint at the start of the trip for you to navigate back to (see section 5-2-1).

3-1-3 Following a route

Preparing

A route is a list of waypoints that the boat can follow (see section 6).

- To create waypoints before creating the route, see section 5-2-1.
- To create a route, see section 6-2-1.

Starting a route from the chart display:

- 1 Go to the chart display.
- 2 Press **MENU** and select **Start Route**.
- 3 Press **▲** or **▼** to highlight the route to follow. Press **ENT**.
4. The Explorer 538/538i asks for the direction to traverse the route.
Select **Forward** (the order the route was created) or **Reverse**.
5. The Explorer 538/538i displays the chart with the route marked and starts navigating from the start of the route.

Starting a route from the routes display:

- 1 Go to the routes display.
- 2 Press **▲** or **▼** to highlight the route to follow. Press **MENU** and select **Start**.
- 3 The Explorer 538/538i asks for the direction to traverse the route.
Select **Forward** (the order the route was created) or **Reverse**.

- 4 The Explorer 538/538i displays a chart with the route marked and starts navigating from the start of the route.

Navigating

The Explorer 538/538i navigates to each waypoint on the route in turn as described in section 3-1-1.

The Explorer 538/538i stops navigating to the waypoint at the end of the current leg and starts the next leg of the route:

- a when the boat comes within 0.025 nm of the waypoint
- b or when the boat passes the waypoint
- c or if you skip the waypoint.

Skipping a waypoint

To skip a waypoint, go to a chart display, press **MENU** and select **Skip**. The Explorer 538/538i starts navigating straight towards the next waypoint on the route.

WARNING

Skipping a waypoint with the autopilot on might result in a sudden course change.

Canceling a route

When the boat has reached the final waypoint, or to stop the boat following the route at any time, cancel the route. Go to a chart display, press **MENU** and select **Cancel route**.

3-2 Chart display

To go to the Chart display, press **DISP**, select **Chart**, then select **Chart**.

A typical chart display shows:

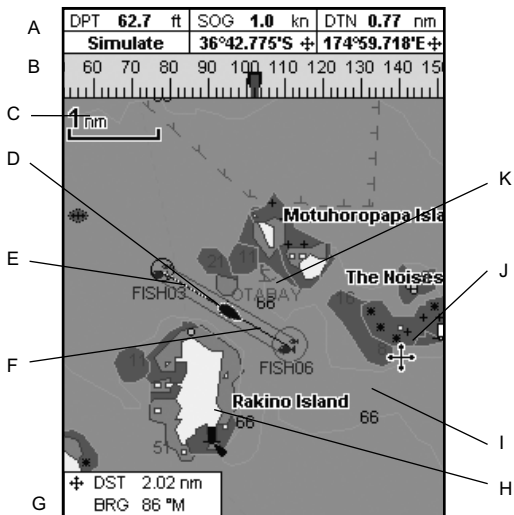

A	Data header. To turn the data off or on or to change what data is displayed, see section 2-8-2
B	Compass (see section 2-8-3)
C	Chart scale (see section 3-2-3)
D	Boat position (see section 3-2-1)
E	Boat track (see section 3-5)
F	Boat course and CDI lines (see Appendix C, CDI). The boat is going to the waypoint called FISH06
G	Distance and bearing of cursor from boat
H	Land
I	Sea
J	The cursor (see section 3-2-1)
K	A typical waypoint (see section 5)
Note: To change the types of information displayed on the chart, see section 17-2.	





3-2-1 Chart modes

The Chart has two modes:

Centre on boat mode

To switch to centre on boat mode in the chart display, press **ESC**. The boat  is at the centre of the chart. As the boat moves through the water, the chart automatically scrolls to keep the boat in the centre of the chart. The cursor (see below) is turned off.



Cursor mode

The keys , ,  and  are called cursor keys. To switch to cursor mode in the chart display, hold down a cursor key. The cursor  appears and moves away from the boat:

- Press the key which points in the direction that the cursor will move, for example press  to move the cursor down.

- Press midway between two of the cursor keys to make the cursor move diagonally.
- Hold a cursor key down to make the cursor move continuously across the display.

In Cursor mode:

- The distance (DST) and bearing (BRG) of the cursor from the boat are displayed at the bottom, left corner of the display.
- The chart does not scroll as the boat moves.
- If the cursor reaches the edge of the display, the chart will scroll.

For example, hold down  to move the cursor to the right side of the display and the chart will scroll to the left.

3-2-2 Latitude and longitude

Latitude and longitude can be displayed in the data header. The display is degrees and minutes to three decimal places, about 2 m (6 ft) resolution. Normally the position is the boat's position, and the latitude and longitude has a boat symbol to show this:

 36° 29.637' N or S Latitude

 175° 09.165' E or W Longitude

If the cursor has been moved in the last ten seconds, then the position is the cursor's position, and the latitude and longitude has a cursor symbol to show this:



 36° 29.841' N or S Latitude

 175° 09.012' E or W Longitude

WARNING

When reading the boat position, make sure the position is not the cursor position.

3-2-3 Chart scale

Press  to zoom in and display a smaller area of the chart in more detail. Press  to zoom out and display a bigger area in less detail.

The chart scale is displayed at the top left of the chart:



3-2-4 Chart symbols and information

The chart will show symbols, such as waypoints and chart symbols (for example buoys, beacons, wrecks and marinas). When the cursor is placed over a symbol for at least two seconds, a data window appears at the bottom left of the display with information about the symbol.

To see stored information about a point on the chart (for example, a chart symbol):

- 1 Move the cursor to that point on the chart.
- 2 Press **MENU** and select Chart info.
- 3 A menu of objects is displayed:
 - i Select an object to display.
 - ii Press **ESC** to return to the menu. Select other objects.
 - iii Finally, press **ESC** to return to the chart.

3-2-5 Finding places

To see places near the boat's position, press **ESC** to switch to centre on boat mode.

To see places near a different point, move the cursor to that point on the chart.

To find and display places of interest:

- 1 Press **MENU** and select **Find**.
- 2 Select the type of place: Waypoints, Routes, Ports, Port services or Tide stations.
- 3 For a Port service, select the type of service to find.
- 4 A list of places is displayed. If there are more places than will fit on the display, press **+** or **-** to scroll up or down a page at a time.

- 5 Select the place and press **ENT**. The chart display changes to show the selected place in the middle of the display.
- 6 To see stored information about the selected place, press **MENU** and select **Chart info** (see section 3-2-4). To display a tide chart for a selected tide station, select **Tide height** from the chart info.

3-3 Distance and bearing calculator

The distance and bearing calculator can plot a course of one or several legs and show the bearing and length of each leg, as well as the total distance along the course. The completed course can be converted into a route.

To use the distance and bearing calculator:

- 1 Press **ESC** until the chart display is displayed. Press **MENU** and select **Distance**.
- 2 Move the cursor to the start of the first leg. It does not matter if this point is a waypoint or not. Press **ENT**.
- 3 To add a leg to the course, move the cursor to the end of the leg. It does not matter if this point is a waypoint or not. The display shows the bearing and length of the leg, as well as the total distance along the course. Press **ENT**.
- 4 To remove the last leg from the course, press **MENU** and select **Remove**.
- 5 Repeat the above two steps to enter the whole course.
- 6 To save the new course as a route, press **MENU** and select **Save**. This also saves any new points on the course as new waypoints, with default names. If necessary, edit the route later (see section 6-2-2) and edit any new waypoints later (see section 5-2-3).
- 7 Finally, press **ESC** to return to the chart display.

3-4 Projected course

If Projected course is turned on, then the Explorer 538/538i will display the projected position based on the course over ground (COG), speed and a specified time. To turn Projected course on and off and to set the time, see section 14-2.

- A Projected position
- B Boat's projected course
- C Boat position

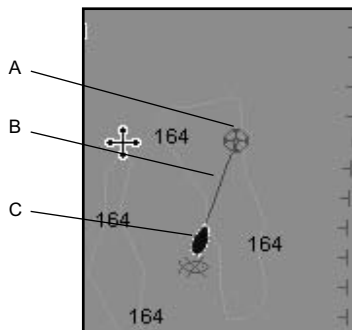

3-5 Tracks and tracking

Tracking records the boat's position to memory at regular intervals, which can be:

- Time intervals.
- Or distance intervals.

The track of where the boat has been can be displayed on the chart. The Explorer 538/538i can display one track while recording another.

To work with tracks, see section 14-5.

The Explorer 538/538i can store five tracks:

- Track 1 can hold up to 2000 points and is intended to record the normal progress of the boat.
- Tracks 2, 3, 4 and 5 can hold up to 500 points each and are intended to record sections to be retraced accurately, for example entering a river mouth.

 **Tip:** Record the tracks in good conditions.

When recording is on and the track becomes full then recording continues and the oldest points in the track are deleted. The maximum length of

a track depends on the selected track interval: a small interval will give a shorter, more detailed track and a long interval will give a longer, less detailed track, as shown in these examples:

Time intervals		
Interval	Track 1	Track 2, 3, 4 or 5
1 sec	33 minutes	8 minutes
10 sec	5.5 hours	1.4 hours
1 min	33 hours	8 hours
Distance intervals		
Interval	Track 1	Track 2, 3, 4 or 5
0.01	20	5
1	2,000	500
10	20,000	5,000

The track lengths are in the current distance units, for example nm.

4 Navigation: Highway display

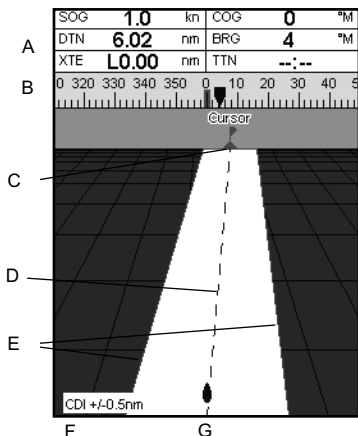

The highway display has a bird's eye view of the boat's course to a destination. To go to the Highway display, press **DISP**, select **Other**, then select **Highway**.

The highway display shows:

- A Optional data header (see section 2-8-3)
- B Optional compass (see section 2-8-4)
- C Destination waypoint
- D Boat's plotted course to destination
- E CDI lines, parallel to the boat's plotted course (see Appendix C, CDI). The CDI lines are like a highway over the water where the boat will move.
- F CDI scale
- G The boat position is at the bottom, centre of the display.

WARNING

The highway display does not show land, dangerous waters or chart symbols.

5 Navigation: Waypoints

A waypoint is a position that you can set on the Explorer 538/538i chart for example a fishing spot or a point on a route. The Explorer 538/538i can have up to 3000 waypoints. A waypoint can be created, changed or deleted. A waypoint has:

- A name (up to eight characters).
- An icon showing what kind of waypoint it is. The available icons are:



- A position.
- A color for the waypoint symbol and name on the chart.

- A type:
 - Normal:** A normal waypoint can be navigated to or included in a route.
 - Danger:** A danger waypoint is a point to avoid. If the boat comes within the danger radius of a danger waypoint the unit can sound an alarm (see section 14-7).
 - A display option:
 - Controls** how the waypoint is displayed when the **Waypoints** setup option is set to **Selected** (see section 14-2):
 - Off:** The waypoint is not displayed.
 - Icon:** The waypoint icon is displayed.
 - I+N (Icon and Name):** The waypoint icon and name are displayed.
- If there are many waypoints, use this feature to select which waypoints are displayed on the chart.

Note: The other choices for Waypoints are **Hide all** and **Show all** (see section 14-2).

5-1 Waypoints display

To go to the waypoints display, press **DISP**, select Other, then select Waypoints. The waypoints display is a list of the waypoints that have been entered, each with waypoint symbol, name, latitude and longitude, distance and bearing from the boat, type and display option.

If there are more waypoints than will fit on the display, press **+** or **-** to scroll up or down a page at a time.

Waypoints			
▼Name	Latitude Longitude	DST(nm) BRG(*M)	Dngr Disp
X AKL0	36°50.338'S 174°46.495'E	7.97 192	No I+N
X AKL1	36°49.945'S 174°49.021'E	6.75 179	No I+N
X AKL2	36°49.079'S 174°49.695'E	5.77 177	No I+N
X AKL3	36°47.849'S 174°49.200'E	4.75 185	No I+N
X AKL4	36°46.974'S 174°49.081'E	4.02 192	No I+N
X AMS0	53°19.180'N 007°18.545'E	10331 282	No I+N
X AMS1	53°19.762'N 007°14.141'E	10335 282	No I+N
X AMS2	53°19.927'N 007°10.720'E	10337 282	No I+N
X AMS3	53°19.927'N 007°07.868'E	10339 282	No I+N

+ to page up / down

5-2 Managing waypoints

5-2-1 Creating a new waypoint

Creating and editing a new waypoint from the chart display

- 1 To create a waypoint at the boat position, press ESC to switch the chart to centre on boat mode.
Or, to create a waypoint at a different point, move the cursor to that point on the chart.
- 2 Press **ENT**.
- 3 A new waypoint, with the default name and data is created.
- 4 Change the waypoint data if necessary (see section 5-2-7). Select Save.

Creating a new waypoint from the waypoints display

- 1 In the waypoints display, press **MENU** and select Create.
- 2 A new waypoint, with a default name and data, is created at the boat position.
- 3 Change the waypoint data if necessary (see section 5-2-7). Select Save.

Note: Waypoints can also be created when a route is created (see section 6-2-1).

WARNING

Do not create a navigation waypoint on land or in dangerous water.

5-2-2 Moving a waypoint

Moving a waypoint from the chart display

- 1 In the chart display, move the cursor to the waypoint to move.
- 2 Press **MENU** and select Move.
- 3 Move the cursor to the new position and press **ENT**.

Moving a waypoint from the waypoints display

To move a waypoint from the waypoints display, edit the waypoint (see section 5-2-3) and change the latitude and longitude.

5-2-3 Editing a waypoint

Editing a waypoint from the chart display

- 1 In the chart display, move the cursor to the waypoint to edit.
- 2 Press **MENU** and select **Edit**.
- 3 Change the waypoint data (see section 5-2-7). Select **Save**.

Editing a waypoint from the waypoints display

- 1 In the waypoints display, press **▲** or **▼** to highlight the waypoint to edit. Press **MENU** and select **Edit**.
- 2 Change the waypoint data (see section 5-2-7). Select **Save**.

5-2-4 Displaying a waypoint on the chart

This goes to the chart display, and shows the selected waypoint at the centre of the display.

- 1 In the waypoints display, press **▲** or **▼** to highlight the waypoint to display. Press **MENU** and select **Display**.

Or, in the Chart display, press **MENU**, select **Find**, then select **Waypoints**. Select a waypoint from the list.

- 2 The Explorer 538/538i switches to the chart display, with the selected waypoint at the centre of the chart.

5-2-5 Deleting a waypoint

A waypoint can not be deleted if the boat is navigating to it or if the waypoint is used in more than one route. A waypoint that is used in one route can be deleted.

⚠ WARNING

When a waypoint is deleted from a route, check that the changed route does not cross land or dangerous waters.

Deleting a waypoint from the chart display

- 1 In the chart display, move the cursor to the waypoint to delete.
- 2 Press **MENU** and select **Delete**.
- 3 Select **Yes** to confirm.

Deleting a waypoint from the waypoints display

- 1 In the waypoints display, press **▲** or **▼** to highlight the waypoint to delete. Press **MENU** and select **Delete**.
- 2 Select **Yes** to confirm.

5-2-6 Deleting all waypoints

- 1 In the waypoints display and press **MENU** and select **Delete all**.
- 2 Select **Yes** to confirm.

5-2-7 Changing a waypoint's data

To change the waypoint data when it is displayed in a window:

- 1 Select the data to change.

Press **ENT**.

Use the cursor keys to change the data.

Press **ENT**.

- 2 If necessary, repeat the above step to change other data.
- 3 Select **Save**.

5-2-8 Sort Waypoints

To change how the waypoints list is displayed:

- 1 Press **MENU** and select **Sort by**.
- 2 Select how to display the list:
Name: In alphabetical order by name.

Icon: Grouped by icon type.

Distance: In order of distance from the boat.

An arrow at the top of a column indicates how the waypoints are sorted.

5-2-9 Navigating to a waypoint

See section 3-1-2.

6 Navigation: Routes

A route is a list of waypoints that the boat can navigate along. Routes can be created, changed and deleted.

The Explorer 538/538i can have up to 25 routes. Each route can have up to 50 waypoints.

A route can:

- Start and stop at the same waypoint.
- Include waypoints more than once.

The Explorer 538/538i can navigate along a route in either direction. Waypoints on the route can be skipped.



Make sure that routes do not cross land or dangerous water.

6-1 Routes display

The routes display is a list of the routes that have been entered, each with route name, start waypoint, end waypoint, number of legs and total distance.

To go to the routes display, press **DISP**, select **Other**, then select **Routes**.

If there are more routes than will fit on the display, press **+** or **-** to scroll up or down a page at a time.

Routes			
Name	Start	Legs	Dist
	End		
AKLDEMO	AKL0	4	
	AKL 4		5.25 nm
AMSDEMO	AMS0	3	
	AMS3		0.45 nm
CAEDEMO	CAB0	4	
	CAB4		0.22 nm
CPTDEMO	CPT0	4	
	CPT4		11.1 nm
GOADEMO	GOA0	4	
	GOA4		4.03 nm
LRHDEMO	LRH0	4	
	LRH4		4.58 nm
OGLDEMO	OGL0	5	
	OGL5		5.05 nm
ROUTE01	WPT001	3	
	WPT004		043.1 nm
SFODEMO	SFO0	5	
	SFO5		3.10 nm

to page up / down

6-2 Managing routes

WARNING

After creating or changing a route, display the route on the chart and check that it does not cross land or dangerous water.

6-2-1 Creating a new route

A. Creating a new route from the chart display while creating the route:

- Press **+** or **-** to change the range; scroll the chart by moving the cursor to the edge of the chart.
- A data box at the bottom left of the display shows the route name and total distance. If the cursor is near a leg, it shows the length and bearing of the leg as well.
- The legs of a route must start and end at waypoints. If a leg does not start or end at an existing waypoint then a new waypoint will be created automatically (to change the new waypoint data, see section 5-2-7).
- You can not use a Danger waypoint in a route.

- 1 In the chart display, press **MENU** and select **New route**.
- 2 The route is given a default name:
 - i Change the name if necessary.
 - ii Select **Ok**.
- 3 To enter the legs of the route:
 - i Move the cursor to the start of the route and press **ENT**.
 - ii A waypoint is created with a default name. to save this waypoint press enter, to edit the waypoint refer to 5-2-7
 - iii Press **ENT** a dotted leg line is displayed from the cursor to the previous waypoint
 - iv Move the cursor to the end of the first leg and press **ENT**.
 - v Repeat i to iv until the last waypoint in the route is placed and saved
 - vi Press **ESC** to complete the route

Menu options while creating a route:

- 1 To add a waypoint to the route
 - i Press **MENU** and select **Add**.

- 2 To insert a waypoint in the route by breaking one leg into two:
 - i Move the cursor to the leg you want to break.
 - ii Press **MENU** and select **Insert**.
 - iii Move the cursor to where the new route waypoint will be.
 - iv Press **ENT**.
- 3 To move a waypoint in the route:
 - i Move the cursor to the waypoint to move.
 - ii Press **MENU** and select **Move**.
 - iii Move the cursor to where the waypoint will be.
 - iv Press **ENT**.
- 4 To remove a waypoint from the route:
 - i Move the cursor to the waypoint to remove from the route.
 - ii Press **MENU** and select **Remove**. The waypoint is removed from the route, but the waypoint is not deleted.
- 5 To start navigating the route
 - i Press **MENU** and select **Start**
- 6 To end creating the route
 - i Press **MENU** and select **End**
- 7 To delete the route
 - i Press **MENU** and select **Delete**
 - ii Select yes to confirm.

 **Tip:** The distance and bearing calculator can also be used to enter a course and save it as a route (see section 3-3).

B. Creating a new route from the routes display

- 1 In the routes display, press **MENU** and select **Create**.
- 2 A new route, with a default name and no waypoints, is displayed.
- 3 To change the route name:
 - i Select the route name at the top of the display and press **ENT**.
 - ii Change the name if necessary.
 - iii Press **ENT**.

- 4 To insert a waypoint in the route:
 - i Select where the waypoint will be:
 - To insert the first waypoint in a new route, select Leg 1.
 - To insert a waypoint at the end of the route, select the unused leg at the end of the list of waypoints.
 - Otherwise, select the waypoint to insert the new waypoint in front of.
 - ii Press **ENT**. A list of waypoints is displayed. Select the waypoint to use.
As waypoints are inserted, the distance and bearing of each leg is shown automatically. If the route has more waypoints than will fit on the display, press **▲** or **▼** to see them.
 - 5 To remove a waypoint from the route:
 - i Select the waypoint to remove.
 - ii Press **MENU** and select **Remove**.
 - 6 Repeat this process until the route is finished.
 - 7 Press **ESC**.
 - 8 Display the route on the chart (see section 6-2-3) and check that the route does not cross land or dangerous water.
- See section 3-1-3.

6-2-2 Editing a route

Editing a route from the chart

- 1 In the routes display, select the route to edit. Press **MENU** and select **Edit** on chart.
- 2 The selected route is displayed on the chart, with a circle around the first waypoint.
- 3 Edit the route as described in section 6-2-1 A, starting at step 4.

Editing a route from the routes display

- 1 In the routes display, press **▲** or **▼** to highlight the route to edit. Press **MENU** and select **Edit**.
- 2 The selected route is displayed: the route name and a list of the waypoints.
- 3 Edit the route as described in section 6-2-1 B, starting at step 3.

6-2-3 Displaying a route on the chart

To view the selected route at the centre of the display:

- 1 In the routes display, press **▲** or **▼** to highlight the route to display. Press **MENU** and select **Display**.
- 2 The Explorer 538/538i displays the selected route on the chart.

Or, in the Chart display, press **MENU**, select **Find**, then select **Route**. Select a route from the list.

6-2-4 Deleting a route

- 1 In the routes display, press **▲** or **▼** to highlight the route to delete. Press **MENU** and select **Delete**.
- 2 Select **Yes** to confirm.

6-2-5 Deleting all routes

- 1 In the routes display, press **MENU** and select **Delete all**.
- 2 Select **Yes** to confirm.

6-2-6 Navigating a route

See section 3-1-3.

7 Satellites

GPS worldwide navigation

The US Government operates the GPS system. Twenty-four satellites orbit the earth and broadcast position and time signals. The positions of these satellites are constantly changing. The GPS receiver analyses the signals from the closest satellites and calculates exactly where it is on earth. This is called the GPS position.

The accuracy of the GPS position is typically better than 10 m (33 ft) for 95% of the time. A GPS antenna can receive signals from the GPS satellites when it is almost anywhere on earth.

DGPS

A DGPS system uses correction signals to remove some of the errors in the GPS position. The Explorer 538/538i can use one of two types of DGPS system:

- WAAS and EGNOS DGPS

WAAS and EGNOS are two satellite based DGPS systems. The correction signals are broadcast by satellites and are received by the Explorer's standard GPS antenna. The accuracy of the corrected GPS position is typically better than 5 m (15 ft) for 95% of the time.

WAAS covers all of the USA and most of Canada. EGNOS will cover most of Western Europe when it becomes operational.

- Differential beacon DGPS

Differential beacons are land based radio transmitters that broadcast correction signals that can be received by a special receiver on the boat. Differential beacons are usually only installed near ports and important waterways, and each beacon has a limited range. The accuracy of the corrected GPS position is typically better than 2 to 5 m (6 to 16 ft).

GPS receiver

Northstar GPS units have a sensitive 12-channel receiver, which tracks signals from all GPS satellites visible above the horizon and uses measurements from all satellites more than 5° above the horizon to calculate the position.

Each time a GPS receiver is turned on, it normally takes about 50 seconds before it outputs the first position. Under some circumstances it will take up to two minutes or longer.

7-1 Satellite display

The satellite display has information about the GPS satellites and GPS position.

To go to the satellite display, press **DISP**, select **Other**, then select **Satellite**.

The satellite display shows:

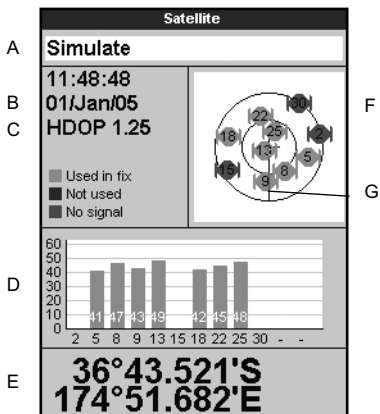

- A** Status of GPS antenna, for example Acquiring, GPS fix, No GPS. If the unit is in Simulate mode it displays Simulate (see section 2-7)
- B** Time and date from GPS satellites. Time is local time (UTC [GMT] plus local offset, see section 14-11)
- C** HDOP: The error in the GPS position caused by satellite geometry. A low value indicates a more precise fix, a high value a less precise fix
- D** Signal strengths of up to twelve visible GPS satellites. The higher the bar the stronger the signal
- E** Boat position
- F** Positions of visible GPS satellites:
- Outer circle is horizon
 - Inner circle is 45° elevation
 - Centre is directly above
 - North is at top of display
- G** If the boat is moving, COG is a line from centre

8 Gauges display

The Gauges display shows boat data, such as water speed, as analog or digital gauges.

To go to the Gauge display, press **DISP** and select Chart, then select Chart+Gauges.

If necessary, press **DISP** twice to switch to the Gauges display (see section 2-8-1).

Before using the Gauge display, set Speed range and Max fuel flow (see section 17-11).

Chart

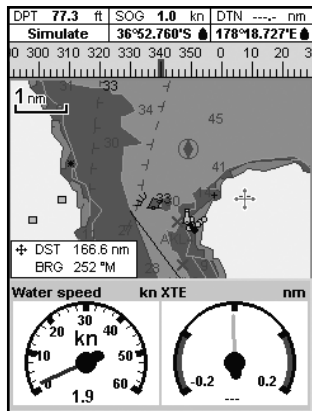

Gauges

Changing the Gauges display

- 1 Go to the Gauges display and press **MENU**.
- 2 To select the gauge type.
 - i Select Gauge type.
 - ii Select Analog (round) or Digital (numbers).
- 3 To select the gauge size.
 - i Select Gauge size.
 - ii Select Small, Medium or Large.
- 4 To change the data displayed:
 - i Select Gauge setup.
 - ii Change a gauge:
 - a) Press the cursor keys to highlight the gauge.
 - b) Press **ENT** to display a menu of data items.
 - c) Select a data item that is available on your system.
 - iii Repeat the above step to set the other gauges. Press **ESC**.
- 5 Press **ESC** to return to the Gauges display.

9 Data display

Data	
Depth ft	Water speed kn
79.9	2.3
Water temp °F	Course °M
68.0	340
Latitude	
36°52.728'S	
Longitude	
178°18.727'E	

The data display has large numeric data fields. To go to the data display, press **DISP**, select **Other**, then select **Data**.

To select what data is displayed:

- 1 Press **MENU** and select **Data setup**.
- 2 Change a data field:
 - i Press the cursor keys to highlight the field.
 - ii Press **ENT** to display a menu of data items.
 - iii Select a data item that is available on your system or select **None** to leave the field empty.
- 3 Repeat the above step to set the other data fields.
- 4 Press **ESC**.

10 Fuel functions and display

The Fuel functions require optional fuel sensors to be installed.

10-1 When you add or remove fuel

When you add or remove fuel in a boat with no SmartCraft fuel tank level sensors, you must tell the Explorer, otherwise **REMAINING**, **RANGE** and the low fuel alarm will be meaningless.

A When you completely fill the tank

- 1 Fill the tank.
- 2 Press **MENU** one or more times until the **Setup** menu is displayed, then select **Fuel**.
- 3 Select **Tank full**.

Note: Underfloor fuel tanks are often difficult to refill to the same level twice, due to air pockets. With underfloor fuel tanks:

- Trim the boat to the same angle in the water each time you follow procedure A.

- Mostly use procedure B below when adding fuel, but completely fill the tank and follow procedure A about every tenth time you add fuel.

B When you part fill the tank

- 1 Before adding fuel, go to the fuel display and write down the value of **Remaining**, which is the amount of fuel now in the tank.
- 2 Add fuel to the tank, writing down how much you add.
- 3 Add together the two figures you have written down, to calculate the amount of fuel now in the tank.
- 4 Press **MENU** one or more times until the **Setup** menu is displayed, then select **Fuel**.

- 5 Set **Remaining** to the amount of fuel that you calculated was now in the tank.

Note: If you follow procedure B every time you add fuel, then a small error will accumulate, because it is hard to measure exactly how much fuel you add. To avoid this, completely fill the tank and follow procedure A about every tenth time you add fuel.

10-2 Fuel display

Fuel display without engine RPM

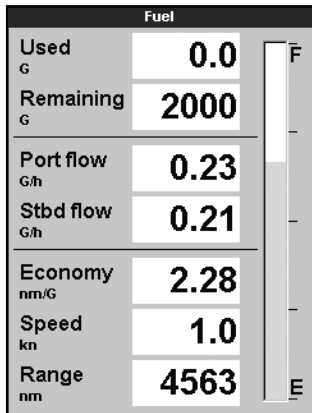

Fuel display with engine RPM

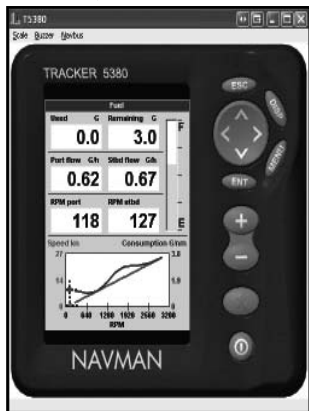

C When you remove fuel

Repeat procedure B, but subtract the fuel you have removed from the original amount of fuel in the tank to calculate the amount of fuel now in the tank.

To go to the Fuel display, press **DISP**, select **Other**, then select **Fuel**. The display is different if engine RPM is available (requires SmartCraft to be installed):

The Fuel display shows Used

The total fuel used since this was last reset with the Clear Used command.

Remaining

The amount of fuel remaining in the tank.

Flow

The fuel consumption per hour. For twin engine installations, the fuel flow for each engine is shown separately. This is useful for checking that both engines are under the same load.

Speed

If the Explorer 538/538i has both GPS and paddlewheel speed available then you can select which to use. The choice affects the calculated Range and Economy (see section 17-5 Speed source).

If the Explorer 538/538i uses a paddlewheel sensor to measure speed, then the speed must be accurately calibrated.

Economy

The the distance travelled per unit of fuel used. The bigger this number, the better the fuel economy. Adjust the throttle and trim to achieve the best economy.

Range

The estimated boat range at the current fuel flow.

10-3 Fuel consumption curves

A fuel consumption curve is a powerful tool for assessing your boat performance in different conditions and for helping you to run at the most economical speed for the conditions. Fuel consumption curves require engine RPM, which requires SmartCraft to be installed.

10-3-1 Making a fuel consumption curve

Making a fuel consumption curve requires running the boat in a straight line through the engine's full RPM range for about 15 minutes. For your first curve, choose a calm day with light wind and little current; have a typical load and a freshly cleaned hull. Then you can make fuel consumption curves for different boat, weather or sea conditions. Compare these with your first curve to see how your boat's performance changes with conditions.

Making a curve

- 1 Start running the boat in a straight line.
- 2 Press **MENU** one or more times until the Setup menu is displayed, then select **Fuel**.
- 3 Select **Fuel consumption curve**, then select **New**.

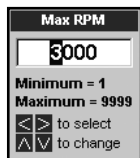

- 4 Enter the comfortable maximum RPM you have measured for the engine. Do not use the maker's maximum RPM.
- 5 The Explorer 538/538i then asks you to set the minimum RPM. Set the throttle for minimum RPM; for a twin engine boat set both engines to about the same minimum RPM.

Now, do not change the engine speed. Wait for about 60 seconds for the boat to stabilise, then press **ENT**. Wait while the Explorer 538/538i records the data.

- 6 The Explorer 538/538i then asks you to set the throttle to achieve a target RPM. For a twin engine boat set both engines to about the target RPM. When the engine RPMs are correct, the Target RPM box will turn green.

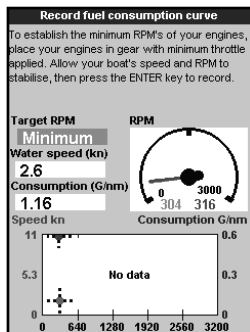

Now, do not change the engine speed. Wait for about 60 seconds for the boat to stabilise, ensuring the Target RPM box stays green. Then press **ENT**. Wait while the Explorer 538/538i records the data.

- 7 The Explorer 538/538i repeats the above step to record data up to the maximum RPM. Then the Explorer 538/538i asks if you want to save the curve. Select **Yes**. The Explorer 538/538i asks for a name for the curve. Change the default name if required, then press **ENT**. The new curve is stored.

Note: To interrupt making the curve at any time, press **ESC**.

10-3-2 Managing fuel consumption curves

Record several curves for different conditions.

Renaming a curve

- 1 Press **MENU** one or more times until the Setup menu is displayed, then select **Fuel**.
- 2 Select **Fuel consumption curve**. Select **Name**, press **ENT** and select the name of the curve to rename.
- 3 Select **Rename** and press **ENT**. Change the name and press **ENT**.

Deleting a curve

- 1 Press **MENU** once or more until the Setup menu is displayed, then select **Fuel**.
- 2 Select **Fuel consumption curve**. Select **Name**, press **ENT** and select the name of the curve to delete.
- 3 Select **Delete** and press **ENT**.

10-3-3 Using fuel consumption curves

A fuel consumption curve is displayed on the fuel display:

- a For a twin engine boat, keep the RPM of both engines similar while using a curve.

Displaying a curve

- 1 To go to the Fuel display, press **DISP**, select **Other**, then select **Fuel**.
- 2 Press **MENU**, press **ENT** and select the name of the curve to display on the fuel display.

Using a curve

Compare your boat's performance now, at the current RPMs, with the boat's performance when you made the curve. You can compare your boat's performance now with a curve made under ideal conditions or with a curve made under similar conditions.

Information in a curve

- A RPM of the boat now. For a twin engine boat, the RPM is the average of the two RPMs.
- B Red curve: boat speeds at different RPMs recorded when you made this fuel consumption curve.

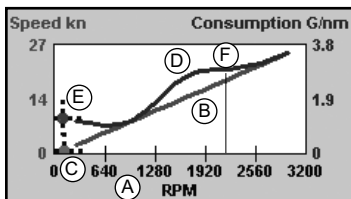

- C Red marker: the boat speed now. This marker is below the red curve, showing that the boat speed now at this RPM is less than when you recorded the curve.
- D Blue curve: fuel consumption at different RPMs recorded when you made this fuel consumption curve.
- E Blue marker: the fuel consumption now. This marker is below the blue curve, showing that the fuel usage now at this RPM is better than when you recorded the curve.
- F If the blue curve has a dip, then running the boat at this RPM will give the best speed for the least fuel consumption.

11 Tides display

The tides display is available on C-MAP charts.
The tides display shows tide information at a tide station for the selected date.

Note: The tides display requires the local time offset to be set to work correctly (see section 14-11)

To show the tides display for the tide station nearest to the boat, press **DISP**, select **Other**, then select **Tides**.

To go to the tides display for any tide station:

- 1 From the chart display, press **MENU** and select **Find**.
- 2 Select **Tide stations**.

- 3 A list of tide stations are displayed. Select the tide station to display. The chart redraws with the tide station centred.
- 4 Press **MENU** and select **Chart info**.
- 5 Select **Tide height**.

Choosing the date of the tide chart

- 1 Press **MENU**.
- 2 Select **Today**, **Next day** or **Prev day**.
To choose a different date from these, select **Set date**, edit the date, press **ENT**.

The tides display shows data for the chosen date

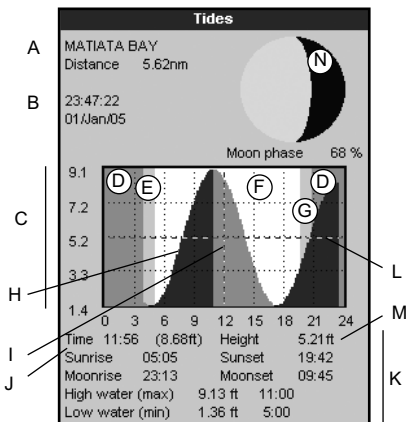

- A Tide station name and distance from boat
- B Current time and chosen date for display
- C Tide chart
- D Night
- E Dawn
- F Day
- G Dusk
- H Tide height
- I Time cursor, a vertical dotted line. Press **←** or **→** to move cursor sideways
- J Time of cursor and tide height at that time
- K Data for the chosen date
- L Tide height cursor, a horizontal dotted line. Press **▲** or **▼** to move cursor up and down.
- M Height of cursor on the tide chart
- N Moon phase for moon at the current time on the chosen date

12 User card display

A C-MAP™ user card is an optional plug-in card that can store data files (see section 1-4). There are three types of files: waypoints, routes or a track.

To go to the user card display, press **DISP**, select Other, then select User card.

Note:

- 1 Before using a user card, remove any chart card and plug the user card in. When you have finished with the user card, remove the user card and replace the chart card (see section 1-3).
- 2 The older 5 volt cards are not supported.

The user card display has:

File list

A list of the files on any user card in the Explorer 538/538i. If there are more files than will fit on the display, press **+** or **-** to scroll up or down a page at a time.

Waypts, Routes

The number of waypoints and routes currently in the Explorer 538/538i.

Track 1 to Track 5

The number of points in tracks 1 to 5 currently in the Explorer 538/538i.

Note:

- 1 To save Explorer 538/538i data onto the user card, use the Save command (see below).
- 2 Data stored on the user card and shown on the file list is not available to be used by the Explorer 538/538i until loaded into the Explorer 538/538i with the LOAD command (see below).

Saving data to the user card

This saves all the Explorer 538/538i's waypoints, all the Explorer's routes or one of the Explorer's tracks to one file on the user card.

- 1 Press **MENU** and select Save.
- 2 Select **Waypts**, **Routes** or **Tracks**.
- 3 For **Tracks**, select the track number to save.
- 4 The new file is created. Change the name if required. The new file appears in the file list.

User card			
Name	Type	Date	Time
Device not present			
In memory		Track 2:	0
Waypts: 57		Track 3:	0
Routes: 11		Track 4:	0
Track 1: 2000		Track 5:	0

Loading data from the user card to the Explorer 538/538i

This loads one file from the user card to the Explorer 538/538i:

- A waypoints file: The new waypoints are added to any existing waypoints in the Explorer 538/538i. If a new waypoint has the same name as an existing waypoint but has different data, the Explorer 538/538i displays both waypoints. Select:

Skip: Do not load the new waypoint.

Replace: Load the new waypoint and replace the existing one.

Skip all: Do not load any new waypoints which have the same names as existing waypoints.

Rplc. all: Load all new waypoints which have the same names as existing waypoints; the new waypoints replace the existing waypoints.

- A routes file: The new routes are added to any existing routes in the Explorer 538/538i. If a new route has the same name as an existing route but has different data then the Explorer 538/538i asks which route to keep.
- A track file: The new track will replace the existing track in the Explorer 538/538i.

To load a file to the Explorer 538/538i:

- 1 Select the file to load.
- 2 Press **MENU** and select Load.

Deleting a file from the user card

- 1 Select the file to delete.
- 2 Press **MENU** and select Delete.
- 3 Select Yes to confirm.

Reading the file information

This reads the file names from the user card and displays them. Reading does not load any file data into the Explorer 538/538i.

- 1 Press **MENU** and select Card.
- 2 Select Read.

Formatting the user card

Formatting prepares a user card for use. Format the card if there is an error message saying that the card is not formatted. Any data files on the card are deleted.

- 1 Press **MENU** and select Card.
- 2 Select Format.
- 3 Select Yes to confirm.

Sorting the file names

This sorts the displayed file names.

- 1 Press **MENU** and select Sort.
- 2 Select sort by Name, Type or Time.

13 About display

About			
Explorer 538i			
Software: 1.3.3, May 10 2005			
Copyright © 2005 Brunswick New Technologies Inc.			
Hardware	18.10	Bootloader	0.0.0
World chart	2.0	Cartography	6.1.7
Card: DM-C030.00 CHARLESTON AREA DEMO			
Waypoints	3000	57	Used
Routes	25	11	Used
Tracks	5	1	Used
Power/comms cable <input checked="" type="checkbox"/> Black			
1	<input checked="" type="checkbox"/> Black	Ground	
2	<input type="checkbox"/> Brown	+9V out	
3	<input type="checkbox"/> White	NMEA out	
4	<input type="checkbox"/> Blue	NavBus-	
5	<input type="checkbox"/> Red	12/24V in	
6	<input type="checkbox"/> Orange	NavBus+	
7	<input type="checkbox"/> Yellow	Ignition	
8	<input type="checkbox"/> Green	Ext Alarm	
Fuel cable <input type="checkbox"/> White			
1	<input checked="" type="checkbox"/> Black	Ground	
3	<input type="checkbox"/> White	NMEA in	

To show the about display, press **DISP**, select Other, then select About.

The about display shows:

- The software version and date.
- The world chart version.
- Any card fitted.
- The number of waypoints, routes and tracks in the Explorer 538/538i
- Wiring information for the Explorer 538/538i connectors.

In the unlikely event of having to contact a Northstar dealer for service, quote the software version number and date.

14 Setting up the Explorer 538/538i

The Explorer 538/538i has a number of advanced features which are set up through the setup menu. We recommend that you become familiar with the operation of the unit using the default settings before making any changes to the data in these menus.

To go to a setup option menu, press **MENU** one or more times to display the setup menu, then select an option.

Note:

- 1 The Setup menu options are explained in the following sections.
- 2 Section 2-1 describes how to set or change data in the setup menus.
- 3 The setup data available will depend on the optional sensors and instruments installed.



14-1 Setup > System

Press **MENU** once or more until the Setup menu is displayed, then select System:

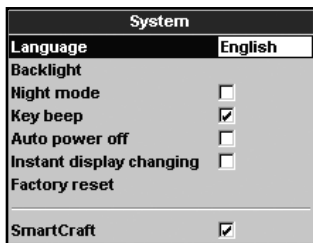

Language

Select the language for the displays. The options are: English, Italian, French, German, Spanish, Dutch, Swedish, Portuguese, Finnish and Greek.

Tip: In case you can't read the current language, the language setting is found at the top of the system menu.

Backlight

Select the backlight level for the keys and display (see also section 2-4)

Night mode

Night mode sets the palette for all displays.

- Normal palette, for daytime
- All displays have a palette optimised for night time.

See also section 2-4. To change only the chart palette, see section 17-2.

Key beep

Enables or disables the beep when a key is pressed.

Auto power off

See section 2-3.

Setup option menus

Factory default settings are shown. The setup data available will depend on the optional sensors and instruments installed.

System
(see 14-1)

System	
Language	English
Backlight	
Night mode	<input type="checkbox"/>
Key beep	<input checked="" type="checkbox"/>
Auto power off	<input type="checkbox"/>
Instant display changing	<input type="checkbox"/>
Factory reset	
SmartCraft	<input checked="" type="checkbox"/>

Chart
(see 14-2)

Chart	
Rotation	North up
Palette	Normal
Map datum	WGS-84
HMEA datum offset	<input type="checkbox"/>
Map shift	OFF
General	
Water	
Other	

General	
Plotter mode	
AntiClutter	<input checked="" type="checkbox"/>
Projected course	Off
CDI scale	0.1 nm
Lat/Lon grid	<input type="checkbox"/>
Boundaries	Auto
Text/Icon Size	Small

Water (14-2)

Water	
Water features	<input checked="" type="checkbox"/>
Bathymetric lines	<input checked="" type="checkbox"/>
Spot soundings	<input checked="" type="checkbox"/>
Bath & sndgs min	0 ft
Bath & sndgs max	50 ft
Tidal flow	<input checked="" type="checkbox"/>

Others (14-2)

Other	
Waypoints	Selected
Names	<input checked="" type="checkbox"/>
Lights	On
Nav-aids	INT
Attention areas	<input checked="" type="checkbox"/>
Land features	<input checked="" type="checkbox"/>

GPS
(see 14-3)

GPS	
GPS source	NMEA
DGPS source	WAAS/EGNOS
Static navigation	Off
Speed filter	5
Course filter	4

Fuel
(see 14-4)

Fuel	
Tank full	
Set remaining	0 G
Clear used	
Tank size	0 G
Num engines	0
Calibrate	
Flow filter	5
Fuel consumption curve	
Speed source	GPS speed

SmartCraft

(see the *SmartCraft Gateway Installation and Operation Manual*)

Track
(see 14-5)

Track	
Record	1
Display	1
Plotting interval	Distance
Distance	0.1 nm
Time	10 sec
Memory used	100%
Send track	
Delete track	

Logs
(see 14-6)

Logs	
Reset trip dist	
Reset total dist	
Reset engine hours	
Trip dist	0.32 nm
Total dist	0.32 nm
Engine hours	0.0 hrs

Alarms
(see 14-7)

Alarms	
Arrival radius	Off
Anchor alarm	<input type="checkbox"/>
XTE	<input type="checkbox"/>
Danger	Off
Low fuel	Off
DGPS	<input checked="" type="checkbox"/>

Units
(see 14-8)

Units	
Distance	nm
Speed	kn
Depth	ft
Fuel	USGal
Compass	°M
Temperature	°F
Wind	True
Pressure	kPa
Baro	mB

Comms
(see 14-9)

Comms	
NMEA out	<input type="checkbox"/>
NMEA data	
Lat/Lon d.p's	3
NavBus	<input checked="" type="checkbox"/>
NavBus group	0

Calibrate
(see 14-10)

Calibrate	
Fuel	
Speed range	Low
Max fuel flow	26 G

Time
(see 14-11)

Time	
Local offset	+00:00
Time format	24 hour
Date format	dd/MMM/yy

Simulate
(see 14-12)

Simulate	
Simulate	<input type="checkbox"/>
Mode	Normal
Speed	1.0 kn
Course	0 °M
Route	AKLDEMO

Factory reset

This option returns all of the Explorer 538/538i settings (except the language, waypoints and routes) to the default factory settings shown on the setup menus.

SmartCraft

- No SmartCraft gateway is fitted. Disable SmartCraft functions.
- Normal SmartCraft operation

See section 15-7.

14-2 Setup > Chart

Press **MENU** once or more until the Setup menu is displayed, then select Chart:

Chart	
Rotation	North up
Palette	Normal
Map datum	WGS-84
NMEA datum offset	<input type="checkbox"/>
Map shift	Off
General	▶
Water	▶
Other	▶

Rotation

The options for chart rotation are:

North up: North is always at the top of the chart display.

Track up: The chart is rotated so that the boat direction is to the top of the display. This option is useful for navigating narrow harbours or rivers. The Explorer 538/538i asks for a course deviation; this is how much the boat direction needs to change to make the chart redraw.

 **Tip:** If the chart redraws too frequently, increase the course deviation setting.

Course up: This option is only available if the boat is navigating to a destination. The chart is rotated so that the plotted course to the destination is vertical.

General	
Plotter mode	<input type="checkbox"/>
AntiClutter	<input checked="" type="checkbox"/>
Projected course	Off
CDI scale	0.1 nm
Lat/lon grid	<input type="checkbox"/>
Boundaries	Auto
Text/icon Size	Small

Palette

Select the Color scheme for the LCD display. The options are:

Normal

Sunlight: Brighter Colors, more visible in sunlight.

Night: Reversed Colors for night, to preserve night vision.

Water	
Water features	<input checked="" type="checkbox"/>
Bathymetric lines	<input checked="" type="checkbox"/>
Spot soundings	<input checked="" type="checkbox"/>
Bath & sndgs min	0 ft
Bath & sndgs max	50 ft
Tidal flow	<input checked="" type="checkbox"/>

Map datum

Explorer 538/538i GPS positions are based on a worldwide reference (datum) known as WGS 84. Most paper charts are based on WGS 84. However, some paper charts are based on other datums. In these cases, the latitude and longitude coordinates of objects on the Explorer 538/538i chart display are different to the latitude and longitude coordinates of these objects on the paper chart. This applies to all objects, such as the boat, waypoints, tracks, lines of latitude and longitude and cartographic features such as land, rocks, buoys and depth contours.

Use **Map datum** to select the Explorer 538/538i map datum to match the datum of the paper chart. Then, the latitude and longitude coordinates of objects displayed on the Explorer 538/538i will change to match the corresponding coordinates on the paper chart.

Other	
Waypoints	Selected
Names	<input checked="" type="checkbox"/>
Lights	On
Nav-aids	INT
Attention areas	<input checked="" type="checkbox"/>
Land features	<input checked="" type="checkbox"/>

Setting map datum

- 1 In the Chart setup menu, select Map datum.
- 2 Select the map datum for the paper chart you are using.
- 3 If you select a datum other than WGS 84 the Explorer 538/538i asks if you want to apply the NMEA datum offset (see below).

WARNING

When you change to a chart with a different datum, change the Explorer 538/538i map datum again.

NMEA datum offset

If you select a map datum other than WGS 84, the map datum offset can be applied to latitude and longitude coordinates sent on the Explorer 538/538i NMEA output:

Latitude and longitude coordinates displayed on any NMEA repeater do not match the coordinates on the Explorer 538/538i. Latitude and longitude coordinates broadcast on any NMEA VHF transmitter will be the same as the coordinates on a WGS 84 chart.

Latitude and longitude coordinates displayed on any NMEA repeaters match the coordinates on the Explorer 538/538i. However, latitude and longitude coordinates broadcast on any NMEA VHF transmitter will be slightly offset from coordinates on a WGS 84 chart.

Map shift

WARNING

Map shift is for eliminating minor offsets. It should not be used if the correct datum is available. Use map shift with caution: incorrect application will cause incorrect boat positions.

Some charts have consistent position errors. To correct this, apply a map shift. After a map shift:

- The positions of cartographic features (such as land, rocks, buoys and depth contours) move on the Explorer 538/538i chart display to where they should be.
- The positions of the boat, waypoints, tracks, and lines of latitude and longitude on the Explorer 538/538i chart display remain unchanged.





Applying a map shift

- 1 Move the boat to a known point on the chart, for example a marina berth.
- 2 In the Chart setup menu, select Map shift.
- 3 Move the cursor to the position on the chart where the boat actually is.
- 4 Press **MENU** and select Set.
- 5 Press **ESC** to set the new map shift. The boat will now be displayed at its actual location.

Clearing the map shift

Clearing the map shift removes any map shift from the cartographic features on the Explorer 538/538i chart display.

- 1 In the Chart setup menu, select Map shift.
- 2 Press **MENU** and select Clear.
- 3 Press **ESC**.

General submenu	
Plotter mode	<input type="checkbox"/> Normal: only scales available on the chart card can be displayed. <input checked="" type="checkbox"/> If you press  or  to select a chart scale which is not available, on the chart card, the chart display will change to this scale but will only display the boat position and track (if enabled). The rest of the display is white with black crosshatch lines and no chart information is displayed. This is useful to zoom to a small scale to track small boat movements or if there is no detailed chart for an area.
Anticlutler	<input type="checkbox"/> Names and icons shown. Note: this is independent of the change in detail shown at different zoom levels. <input checked="" type="checkbox"/> hides some less important names and icons to make the chart clearer.
Value added data	<input checked="" type="checkbox"/> Non marine chart data shown
Projected course	The Explorer 538/538i can estimate the course after a given time, based on the current speed and heading (see section 3-4). The options are 2 minutes, 10 minutes, 30 minutes, 1 hour, 2 hours or Off.
CDI scale	See Appendix C. The options are 0.05, 0.1, 0.2, 0.5, 1.0, 2.0, 4.0 and 10.0 distance units.
Lat/lon grid	<input checked="" type="checkbox"/> displays a latitude and longitude grid.
Boundaries	Displays boundaries around areas where more detailed chart coverage is available: Auto shows the next four detail levels; On shows all.
Text/icon size	Select the size of chart text and icons.
Water submenu 	
Water features	<input checked="" type="checkbox"/> displays marine sediment labels (for example, M shows areas of mud) and tide station icons
Bathymetrics	Displays underwater depth contours between Bath & sndgs min and max .
Spot soundings	Displays depth soundings between Bath & sndgs min and max .
Bath & dndgs min	The minimum depth for Bathymetrics and Spot soundings .
Bath & dndgs max	The maximum depth for Bathymetrics and Spot soundings .
Tidal flow	<input checked="" type="checkbox"/> displays dynamic tide flows: arrows on a chart showing the present tide stream and orientation (requires a GPS fix and an NT-MAX card)
Other submenu	
Waypoints	Displays waypoints: Hide all only displays waypoints on any selected route; Selected displays waypoints with their display option set to Icon or I+N (Icon and Name) (see section 5).
Names	<input checked="" type="checkbox"/> displays place names.
Lights	Displays lighthouses: No sector hides any light sectors; On shows all data.
Nav-aids	Displays signals (fog, radar, radio stations) and bouys. Int and US select the icon format; Simpl draws simpler icons.
Attention areas	<input checked="" type="checkbox"/> displays attention area boundaries and information icons  ; attention areas are important areas, such as restricted anchorages or shallow areas.
Land features	<input checked="" type="checkbox"/> displays land features, for example regions, rivers, roads, railways, airports

14-3 Setup > GPS

Press **MENU** once or more until the Setup menu is displayed, then select GPS:

GPS	
GPS source	NMEA
DGPS source	WAAS/EGNOS
Static navigation	Off
Speed filter	5
Course filter	4

GPS Source

- **Internal:** Use the internal GPS antenna (Explorer 538i) or the external GPS antenna supplied (Explorer 538) (see section 15-5).
- **NMEA:** Use an external GPS or DGPS source connected via NMEA (see section 15-9).
- **NavBus:** Use an external GPS or DGPS source connected via NavBus (see section 15-8).

DGPS Source

Enables or disables the satellite based DGPS correction (see section 7). The options are None or WAAS/EGNOS. Do not enable WAAS/EGNOS outside their coverage areas or the accuracy of the position might be degraded.

WAAS covers all of the USA and most of Canada. To use WAAS, the GPS antenna must have a clear view of the sky towards the equator. EGNOS will cover most of Western Europe when it becomes operational.

Restart GPS

Restarts the internal GPS receiver for servicing or troubleshooting. The GPS receiver takes up to three minutes to restart. The satellite display shows the status of the GPS receiver (see section 7). Restart the GPS if the receiver has not been used for some time and is taking a long time to get a GPS fix.

Static Navigation

When the boat stops or moves very slowly, the calculated GPS speed and course become erratic. Static navigation is a number, and the options are:

- 0.01 to 99.9: If the boat speed is slower than this, the speed is displayed as zero and the course stays unchanged.
- 0 (Off): The calculated speed and course are always used.

Speed and Course Filter

Waves and wind cause the boat speed and course to fluctuate slightly. To give stable readings, the Explorer calculates these values by taking several measurements and averaging them.

- A lower value averages measurements over a shorter period of time. This gives the most accurate value but has the most fluctuations.
- A higher value averages measurements over a longer period of time. This gives the most stable value but will ignore some true speed changes.

Set the Speed and Course filters to the lowest values which give stable readings. The range of each filter is 1 to 60 seconds or Off (0).

14-4 Setup > Fuel

Fuel setup requires optional petrol/gasoline or SmartCraft sensors to be installed. Set Num engines first to enable the fuel functions.

Press **MENU** one or more times until the Setup menu is displayed, then select **Fuel**:

Fuel	
Tank full	
Set remaining	0 G
Clear used	
Tank size	0 G
Num engines	0
Calibrate	
Flow filter	5
Fuel consumption curve	
Speed source	GPS speed

WARNING

Fuel consumption can change drastically depending upon the boat loading and the sea conditions. Always carry adequate fuel for the journey, plus a reserve.

Tank full

Tells the Explorer 538/538i you have filled a fuel tank (see section 10-1).

Set remaining

Tells the Explorer 538/538i you have added or removed fuel (see section 10-1).

Clear Used

Select **Clear** used to set **Used** (the amount of fuel used) to zero. Do this to start measuring the amount of fuel used over a certain time or distance.

Tank size

Enter the capacity of the fuel tank. Northstar recommends measuring tank size by draining the fuel tank, filling it to capacity and using the fuel dispenser's reading. Beware of air pockets, especially in underfloor tanks.

Num. engines

Set the number of engines to 0, 1 or 2. If 0 is selected the fuel features are turned off.

Calibrate

SmartCraft fuel sensors are factory calibrated and should never need recalibrating. Calibrating Northstar petrol/gasoline sensors gives more accurate fuel values.

Twin engine installations require each fuel transducer to be calibrated. This can be done at the same time with two portable tanks or at different times using one portable tank.

Calibrating the fuel transducer(s) requires accurate measurement of the fuel consumption. This is best done using a small portable tank. At least 4 gallons (15 litres) of fuel should be used to ensure an accurate calibration.

It is often very difficult to fill underfloor tanks to the same level twice due to air pockets, so the more fuel used, the more accurate the calibration.

To calibrate the fuel transducer(s), perform the following steps:

1. Record the level of the fuel in the tank(s).
2. Connect the portable tank(s) to the engine through the fuel transducer(s).
3. Run the engine at normal cruising speed until at least 4 gallons (15 litres) of fuel has been used per engine.
4. Check the actual amount of fuel used per engine by refilling the portable tank(s) to the original level and noting the reading(s) from the fuel dispenser's gauge.
5. Select **Fuel**. Use the cursor keys to change the reading for each engine to match that on the fuel dispenser's gauge.
6. Press **ENT** when the reading is correct.

Note: If the fuel calibration options appear to give erroneous readings after a while, first check that the fuel sensor has been installed correctly according to the installation instructions supplied with it, then see Appendix B - Troubleshooting.

Flow filter

Most engines do not draw fuel from the tank at a steady rate. To give a stable fuel flow reading, the Explorer calculates the flow value(s) by taking several measurements and averaging them. Use the Flow filter to set the period over which the fuel flow is averaged.

The Flow filter can be set from 0 to 30 seconds. Use the lowest value which gives a stable flow. Usually a value of 5 to 10 seconds will give a satisfactory result for two-stroke carburettor engines. Fuel injected or four-stroke engines may require a larger value.

This setting affects the Fuel flow and Fuel economy reading on the Fuel display but it does not affect the Fuel used reading.

Fuel consumption curve

See section 10-3.

14-5 Setup > Track

Press **MENU** one or more times until the Setup menu is displayed, then select **Track** :

Track	
Record	1
Display	1
Plotting interval	Distance
Distance	0.1 nm
Time	10 sec
Memory used	100%
Send track	
Delete track	

Tracking records and displays the boat's course on the chart (see section 3-5). Five different tracks can be recorded: track 1 has up to 2000 points and tracks 2, 3, 4 and 5 have up to 500 points each.

Record

Off : The Explorer 538/538i tops recording a track.

1 to 5 (select a track number): The Explorer 538/538i starts recording the boat's course into the selected track.

Display

Off : No track is shown on the chart.

1 to 5 (select a track number): The selected track is shown on the chart.

Speed source

If both paddlewheel sensor and GPS speeds are available, select the source of speed readings for fuel calculations. If there is a current or tide, these speeds and the fuel calculation results will be different.

Water speed : Use paddlewheel sensor speed (boat speed through the water). This gives a more accurate value for Economy.

GPS : Use GPS speed (boat speed relative to land). This gives a more accurate value for Range.

Plotting Interval

The options are **Distance** or **Time** .

Distance

Select the distance plotting interval: 0.01, 0.05, 0.1, 0.5, 1.0, 2.0, 5.0 or 10.0 distance units.

Time

Select the time plotting interval: 1, 5, 10 or 30 seconds or 1 minute.

Memory used

The percentage of memory used in the track being recorded.

 **Tip**: Use the user card display to check the number of points recorded in each track (see section 14).

Send track

This option is included for compatibility with older units. For information, see your Northstar dealer.

Delete track

The data in the track selected for Record (see above) is deleted.

14-6 Setup > Logs

Press **MENU** one or more times until the Setup menu is displayed, then select Logs :

Logs	
Reset trip dist	
Reset total dist	
Reset engine hours	
Trip dist	0.32 nm
Total dist	0.32 nm
Engine hours	0.0 hrs

The values can be changed independently of each other. These log values are saved when the unit is turned off.

Reset trip dist

This resets the trip distance to zero.

Reset total dist

This option resets the total distance to zero.

Reset engine hours

Use this option to reset the engine hours to zero. This can be useful after an engine service or to count the engine hours between service intervals.

14-7 Setup > Alarms

Press **MENU** one or more times until the Setup menu is displayed, then select Alarms :







Alarms	
Arrival radius	Off
Anchor alarm	Off
XTE	<input type="checkbox"/>
Danger	Off
Low fuel	Off
DGPS	<input checked="" type="checkbox"/>

All alarms except Loss of GPS fix can be turned on (enabled) or off (disabled).

For the XTE and Loss of DGPS fix alarms, select to turn the alarm on or select

to turn the alarm off. For the other alarms, enter a trigger value to turn the alarm on. The alarm will sound each time the alarm value equals the trigger value. For example, the Danger alarm will sound if the boat comes closer to a danger waypoint than the trigger value and the Anchor alarm will sound if the boat moves by more than the trigger value. To turn these alarms off, enter a trigger value of 0 (zero).

Icons for alarms that are on can be displayed in the data header (see section 2-8-2). An alarm icon is normally black and turns red when the alarm sounds.

Symbol	Alarm	Alarm sounds when it is on and the:
	Arrival radius	boat is closer to the destination or to a waypoint than the alarm trigger value
	Anchor alarm	boat moves by more than the alarm trigger value
	XTE	boat moves off course by more than the CDI scale (see section 14-2)
	Danger	boat comes closer to a danger waypoint than the alarm trigger value
	Low fuel	fuel remaining equals the alarm trigger value
	Loss of DGPS fix	Explorer 538/538i can not receive the DGPS signal (beacon, WAAS or EGNOS)
	Loss of GPS fix	Explorer 538/538i can not receive the GPS signal (this alarm is always on)

14-8 Setup > Units

Press **MENU** one or more times until the Setup menu is displayed, then select Units:

Units	
Distance	nm
Speed	kn
Depth	ft
Fuel	USGal
Compass	°M
Temperature	°F
Wind	True
Pressure	kPa
Baro	mB

The default units are shown above.

Distance

nm (nautical miles), mi (miles) or km (kilometres)

Speed

kn (knots), mph (miles per hour) or kph (kilometres per hour)

14-9 Setup > Comms

Use this feature when the Explorer 538/538i is connected to other Northstar instruments through NavBus or any compatible NMEA instrument.

Press **MENU** once or more until the Setup menu is displayed, then select Comms:

Comms	
NMEA out	<input type="checkbox"/>
NMEA data	<input type="checkbox"/>
Lat/Lon d.p.'s	3
NavBus	<input type="checkbox"/>
NavBus group	0

NMEA out

NMEA is generally used with third party instruments (see section 15-9). Select this to transmit NMEA sentences, for example to an autopilot.

NMEA data

Use this to specify which NMEA sentences will be transmitted (see section 15-9 and Appendix A).

Depth

ft (feet), m (metres) or fa (fathoms)

Fuel

Litres, USGal (US gallons) or ImpGal (Imperial Gallons)

Compass

°T (True north) or °M (Magnetic north)

Temperature

°F (Fahrenheit) or °C (Celsius)

Wind (optional)

Requires a wind instrument: True or App (Apparent)

Note: that the units for wind speed are the speed units.

Pressure

Requires SmartCraft: kPa or psi

Baro (Barometric pressure)

Requires a Northstar VHF receiver connected by NavBus: InHg or mB.

Lat/lon dps

Select the number of decimal points used for latitude and longitude transmitted in NMEA sentences.

NavBus

NavBus is the preferred method for connecting the Explorer 538/538i to other Northstar instruments. Select this if the instruments are connected using NavBus.

NavBus Group

Use this when a group of Northstar instruments are connected together using NavBus, to specify a group of instruments for backlighting, if required. Then, if the backlight setting on one instrument in the group is adjusted, the other instruments change automatically. Otherwise, select 0. See section 15-8.

14-10 Setup > Calibrate

Press **MENU** once or more until the Setup menu is displayed, then select Calibrate:

Calibrate	
Fuel	
Speed range	Low
Max fuel flow	26 G

14-11 Setup > Time

Press **MENU** once or more until the Setup menu is displayed, then select Time:

Time	
Local offset	+00:00
Time format	24 hour
Date format	dd/MMM/yy

14-12 Setup > Simulate

Simulate mode is a way of becoming familiar with the Explorer 538/538i (see section 2-7).

Press **MENU** once or more until the Setup menu is displayed, then select Simulate:

Simulate	
Simulate	<input type="checkbox"/>
Mode	Normal
Speed	1.0 kn
Course	0 °M
Route	AKLDEMO

Simulate

- Turn simulate mode off
- Turn simulate mode on

Fuel

See section 14-4.

Speed range

The maximum reading to display on an analog boat speed gauge (see section 10). Choose a range suitable for your boat.

Max fuel flow

The maximum fuel flow from the fuel tank.

Local offset

The difference between local time and UTC (GMT). Change local offset when daylight saving time starts and ends. The range is 0 to \pm 13 hours, in 30 minute steps.

Time format

The options are 24 hour or 12 hour.

Date format

The options are dd/MMM/yy, MMM/dd/yy, dd/MM/yy or MM/dd/yy.

WARNING

Never have simulate mode on when the Explorer 538/538i is navigating on the water.

Mode

There are two choices for Mode:

1 Normal

Simulates the boat moving from the selected start point at the given speed and heading. The options required for Normal are:

Speed: The simulated boat speed to use.

Course: The simulated bearing for the boat to follow.

Note: To select the start point, go to the chart display before starting the simulation. Then:

- To start the simulation from the boat position, press **ESC** to switch to centre on boat mode.
- To start the simulation from a different point, move the cursor to that point on the chart.

 **Tip:** To calculate a course, use the cursor (see section 3-3).

 **Tip:** As the boat moves, vary Course to simulate the boat moving off course.

2 Demo

Simulates a boat moving along a route and automatically displays different Explorer 538/538i functions.

The options required for Demo are:

Speed: The simulated boat speed to use.

Route: The route to follow.

15 Installation

Correct installation is critical to the performance of the unit. It is vital to read the entire installation section of this manual and the documentation that comes with the antenna and any other units before starting installation.

15-1 Installation: What comes with the Explorer 538/538i

- Explorer 538 or 538i display unit
- Dust cover for display unit
- Blanking caps for unused connectors
- Power cable
- Mounting bracket (screws included)
- Flush mounting kit
- Northstar 133 GPS antenna for Explorer 538 only; the Explorer 538i has a built in GPS antenna.
- Warranty registration card
- This manual



15-2 Installation: Options and Accessories

- C-MAP™ NT-MAX, NT+ or NT chart cards.
- C-MAP™ user cards (3 V) for storing data. (The older 5 volt cards are not supported)
- Northstar carry bag.
- Northstar NavBus junction boxes simplify wiring, particularly if several instruments are connected. For more information, see the *NavBus Installation Manual*.

Optional sensors and instruments

External alarms: Lights or sounders in the boat to sound alarms through the boat (see section 15-4).

GPS or DGPS antenna: For GPS navigation, see section 15-5.

Fuel sensors: For fuel functions. The Explorer 538/538i can use these optional fuel flow sensors, fitted to one or two engines:

- Northstar petrol/gasoline sensors (see section 15-6)
- SmartCraft fuel sensors (see section 18-11)

SmartCraft: With one or two SmartCraft capable Mercury engines, the Explorer 538/538i can display engine data and trim and can control troll speed (see section 18-10).

Other instruments: The Explorer 538/538i can receive data from other instruments and send data to other instruments by NavBus or NMEA (see sections 18-12 and 18-13).

Please consult your Northstar dealer for more information.

Connections

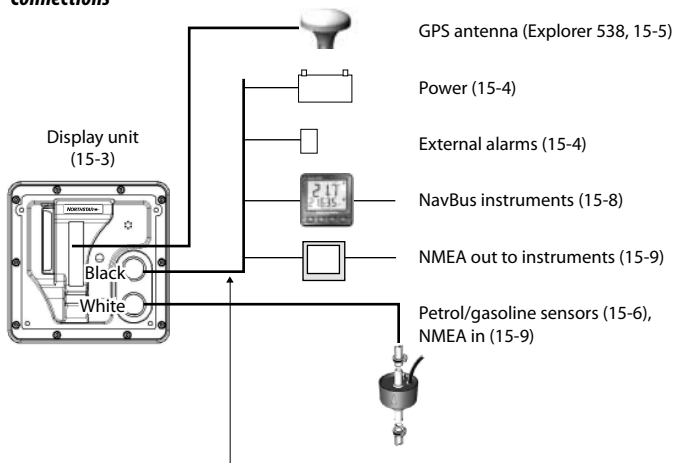

Power/data cable

Pin	Wire	Function
1	Black	Ground: - power in, NMEA ground. (The cable has two black wires which are connected inside the cable and it does not matter which black wire you use)
2	Brown	Power out, 9 V DC (not used)
3	White	NMEA out
4	Blue	NavBus-
5	Red	+ power in, 10 to 16 V DC
6	Orange	NavBus+
7	Yellow	Auto power in
8	Green	External alarm out, 30 V DC 200 mA maximum.

15-3 Installation: The display unit

Select a position for the display unit:

- At least 4" (100 mm) away from the compass, at least 12" (300 mm) away from any radio transmitter and at least 4 ft (1.2 m) away from any antenna.
- Easy to read and operate. If possible, mount the display unit in front of the navigator or to the right of the navigator because the LCD display is more readable from these positions.
- Not exposed to the direct sun or water and protected from physical damage during rough sea passages.
- Easy to access the 12 V DC power source and convenient to route the transducer cables.

For the Explorer 538i, with the internal GPS antenna:

- The display unit must have a good view of the sky and horizon. The view should not be blocked by large parts of the superstructure.
- The unit can be under glass, perspex, fibreglass or fabric, but not under metal or wood.
- Do not mount the unit within 3 m (10 ft) of a radio transmitter antenna or within 0.5m (20 in) of the plane of a radar antenna.

There are two mounting arrangements:

1 Flush Mounting

Requires a solid panel with access behind for wiring and mounting screws. After flush mounting, the display unit cannot be tilted or moved after installation to reduce any unwanted glare or reflections. Carefully select the best viewing position before installation. This would generally be in a shaded area.

- 1 Cut a hole in the bulkhead for the display unit using the flush mount template.
- 2 Drill four holes for the mounting studs using the flush mount template.
- 3 Screw the four studs into the brass inserts in the back of the display unit.
- 4 Sit the display unit in place and fit the washers and nuts to the studs.

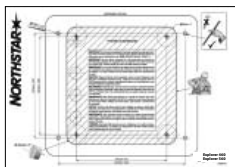

2 Bracket Mounting

Requires a panel for mounting the bracket. Ensure that the panel is not likely to deform and is not subject to excessive vibration. The bracket can be tilted and rotated. The display unit can be removed when it is not in use.

- 1 Hold the bracket in place and mark the screw holes.
- 2 Drill the screw holes and screw the bracket in place. Do not overtighten the screws or the display unit might not rotate.
- 3 Hold the display unit in place on the mounting bracket shaft. Hand tighten the knob on the mounting bracket.



15-4 Installation: Power/Data cable

The power/data cable has a black locking collar and flying leads.

- 1 Wire the Explorer 538/538i for auto power to have the Explorer 538/538i turn on with the boat's ignition switch or to record engine hours or if the Explorer 538/538i must add up the total fuel used (for example if Northstar petrol/gasoline fuel sensors are installed or if SmartCraft is installed without fuel tank level sensors). Otherwise wire for basic power (for more information, see section 2-2).

Basic power

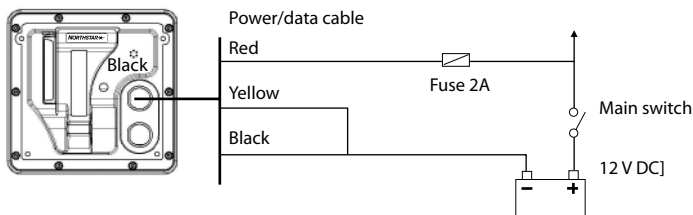

Auto power

During setup, set up Auto power off (see sections 2-3 and 17-1)

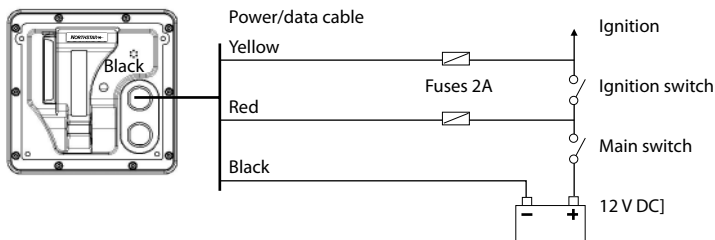

- 2 Wire any external alarm beepers or lights. The alarm output switches to ground to sound the alarm. If the current is more than 200 mA, fit a relay.
- 3 Connect the power/data cable to the black display unit connector; turn the collar to lock the connector.

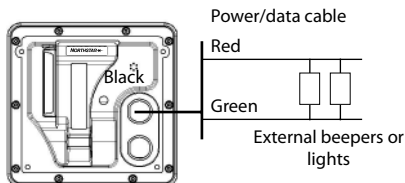

15-5 Installation: GPS antenna

Selecting an antenna

Fit one of these GPS antennas:

- Normally use the internal GPS antenna (Explorer 538i) or the GPS antenna supplied (Explorer 538).
- An optional differential beacon DGPS antenna to give enhanced accuracy within range of land based differential beacons in areas where WAAS or EGNOS are not available. Such a DGPS antenna has both a GPS receiver and a beacon receiver, and it automatically applies the beacon correction to the GPS position.
- A compatible GPS or DGPS instrument or antenna connected by NavBus (see section 15-8) or NMEA (see section 15-9). In this case, the Explorer 538/538i does not need its own antenna.

Note:

- The Explorer 538/538i can apply the WAAS and EGNOS DGPS corrections to any GPS antenna.
- To configure the Explorer 538/538i for different antenna options, see section 14-3.

For more information, contact your Northstar dealer.

Installing an antenna

If an external antenna is required, install the antenna and fit the antenna cable back to the display unit. Follow the instructions in the manual supplied with the antenna. Fit an optional Northstar extension cable if required.

Connect the Explorer 538 external antenna to the gold Explorer connector:

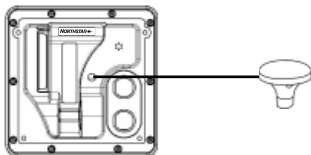

During setup, configure the Explorer for the chosen antenna, see section 17-4.

15-6 Installation: Northstar petrol/gasoline sensors

Fit the optional petrol/gasoline fuel kit following the instructions supplied with the kit.

Note:

- SmartCraft engines have fuel flow sensors, therefore Northstar fuel sensors are not required as well.
- For dual engines, fit two kits.
- Wire the Explorer 538/538i for auto power (see section 15-4).

During setup:

- a set up Auto power off (see sections 2-3 and 17-1)
- b set the fuel data (see section 14-4)

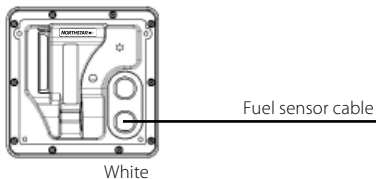

15-7 Installation: SmartCraft

If the boat has one or two SmartCraft capable Mercury petrol/gasoline engines, connect the Explorer 538/538i to the SmartCraft engines with an optional SmartCraft gateway. The display unit can display engine data and trim and can control troll speed.

Note:

- Fit a single gateway for single engines and a dual gateway for dual engines.
- SmartCraft engines have fuel flow sensors, therefore Northstar fuel sensors are not required as well.
- If the fuel tank does not have SmartCraft level sensors, wire for auto power (see section 15-4).

During setup enter the SmartCraft setup data. For information on installing, setting up and using SmartCraft, see the *SmartCraft Gateways Installation and Operation Manual*.

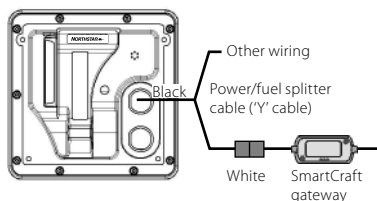

15-8 Installation: Other NavBus instruments

NavBus is Northstar's system for connecting instruments together to interchange data and share transducers. When instruments are connected by NavBus:

- If the units, alarms or calibration are changed in one instrument, then the values will automatically change in all other instruments of the same type.
- Each instrument can be assigned to a group of instruments. If the backlight is changed in an instrument in group 1, 2, 3 or 4 then the backlight will automatically change in the other instruments in the same group.

If the backlight is changed in an instrument in group 0 then no other instruments are affected.

- If an alarm sounds, mute it by clearing the alarm on any instrument which can display that alarm.

NavBus and the Explorer 538/538i

The Explorer 538/538i can:

- Display wind speed and direction from an optional Northstar Wind instrument.
- Receive and display depth from an optional Northstar depth instrument.
- Receive and display boat speed and water temperature from a paddlewheel sensor on an optional Speed instrument.

- Receive barometric pressure from an optional Northstar VHF radio. The Explorer can display:
 - Baro:** barometric pressure
 - Baro history:** barometer history
 - Weather:** a prediction, based on changes in barometric pressure
 - Fish forecaster:** a prediction based on changes in barometric pressure
- Receive data from an optional GPS or GPS/DGPS source.
- Send data to optional Northstar instruments, for example to a repeater.

During setup for NavBus instruments, set NavBus to and assign the instrument a NavBus group number (see section 14-9)

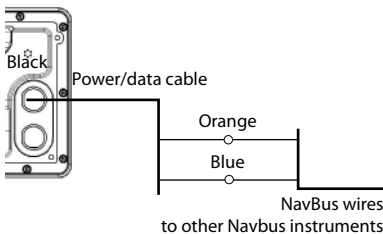

15-9 Installation: Other NMEA instruments

NMEA is an industry standard for interconnecting instruments. It is not as flexible or as easy to install as NavBus. The Explorer 538/538i can:

- Receive and display wind speed and direction from an optional compatible wind instrument.
- Receive and display depth, paddlewheel boat speed and water temperature from an optional compatible instrument.
- Receive data from an optional compatible GPS or GPS/DGPS source.
- Send GPS position and other navigation data to an autopilot or other instrument. An autopilot requires APB, APA and VTG sentences (see section 14-9).

For information on sending NMEA data to the Explorer, see your Northstar dealer.

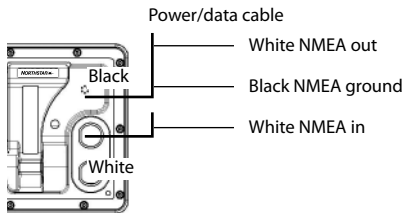

During setup to send NMEA data to other instruments, set NMEA out to and specify the NMEA data to send (see section 14-9).

15-10 Installation: Setup and test

Setup and test

- 1 Put a blanking cap on any unused connector on the back of the display unit. Ensure all connectors are plugged in and the display unit is in place.
- 2 If the display unit is bracket mounted, adjust tilt and rotation for best viewing and hand tighten the knob.
- 3 Insert any required C-MAP chart card (see section 1-3).
- 4 Turn the instrument on (see section 2-3). When the Explorer 538/538i is turned on for the first time, it displays an installation menu:
 - i Select the language to use.
 - ii Change the data if necessary (see section 2-1)
 - iii When the setup data is correct, press .
- 5 Enter setup data to set up the Explorer 538/538i to your requirements and to set up any optional sensors or instruments (see section 14).
- 6 At the satellite display, check that it picks up GPS satellites. Wait for the GPS receiver to start up and the fix type to change from 'Acquiring' to 'GPS fix'. This should take less than two minutes (see section 7).
- 7 Go on a test run to check that the navigation equipment works correctly, particularly when a radio transmitter or radar is used.

This data can be changed later (see section 14).

Appendix A - Specifications

GENERAL

Size: 126 mm H x 126 mm W x 65 mm D (5.0" x 5.0" x 2.6")

Display: 3.8" diagonal, TFT Color, 240 x 320 pixels

Backlight: Display and keys

Supply voltage

10 to 16 V DC.

Supply current: at 13.8 V

120 mA min - no backlighting

220 mA max - full backlighting

External beeper or light output: Switched to ground to sound alarm, 30 V DC, 200 mA maximum.

Operating temperature

0° to 50°C (32° to 122°F)

ALARMS:

- User set: Arrival radius, anchor, XTE, danger, low fuel (optional), loss of DGPS fix
- Fixed: Loss of GPS fix

GPS NAVIGATION

Chart card: C-MAP™ NT-MAX, NT+ or NT

User card: 3.3 V C-MAP™

Waypoints: Up to 3000, with default or user-defined alphanumeric names up to eight characters.

Routes: 25 Routes, with up to 50 points each

Tracks: By time or distance, one track of 2000 points and four of 500 points.

Chart datums

- 121 Chart datums (see next page)
- One user-defined map shift.

Chart scale: 0.05 to 4096 nm for chart (chart dependent) down to 0.01 nm in plotter mode.

FUEL COMPUTER

(Optional fuel sensor(s) required)

Engine types:

- Outboard carburetted two stroke and EFI petrol/gasoline engines: 50 to 300 hp.
- Outboard four stroke petrol/gasoline engines: 90 to 300 hp.
- Inboard petrol/gasoline engines: 70 to 400 hp.

Flow rate:

- Minimum: 5 litres per hour (1.3 U.S. gallons per hour).
- Maximum: 130 litres per hour (34 U.S. gallons per hour).

COMMUNICATIONS

NavBus

Connection to other Northstar instruments.

NMEA

- NMEA 0183 ver 2 4800 baud
- Inputs from compatible instruments: DBT, DPT (preferred), GGA, GLL, GSA, GSV, MTW, MWV, RMC, VHW, VTG
- Outputs, for compatible instruments: APA, APB, BWR, GGA, GLL, GSA, GSV, RMB, RMC, VTG, XTE

STANDARDS COMPLIANCE

EMC:

- USA: FCC Part 15 Class B.
- Europe: (CE) EN301843-1:2004-06.
- New Zealand and Australia: (C Tick) EN60945 9.2 & 9.3.

Environment: IPx6/IPx7/CFR46 (with card holder and connections in place).

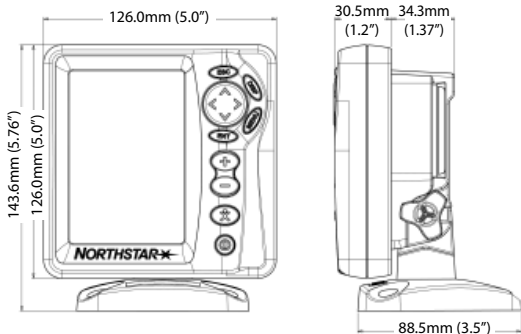

List of datums

Adindan	Afgooye	AIN EL ABD 1970
American Samoa 1962	Anna 1 Astro 1965	Antigua Island Astro 1943
ARC 1950	ARC 1960	Ascension Island 1958
Astro Beacon 'E' 1945	Astro DOS 71/4	Astro Station 1952
Astro Tern Island (Frig) 1961	Australian Geodetic 1966	Australian Geodetic 1984
Ayabelle Lighthouse	Bellevue (IGN)	Bermuda 1957
Bissau	Bogota Observatory	Bukit Rimpah
Camp Area Astro	Campo Inchauspe 1969	Canton Astro 1966
Cape	Cape Canaveral	Carthage
Chatham Island Astro 1971	Chua Astro	Co-ord. Sys.1937 Estonia
Corrego Alegre	Dabola	Deception Island
Djakarta (Batavia)	DOS 1968	Easter Island 1967
European 1950	European 1979	Fort Thomas 1955
Gan 1970	Geodetic Datum 1949	Graciosa Base Sw 1948
Guam 1963	Gunung Segara	GUX 1 Astro
Herat North	Hermannskogel	Hjorsey 1955
Hong Kong 1963	Hu-Tzu-Shan	Indian
Indian 1954	Indian 1960	Indian 1975
Indonesian 1974	Ireland 1965	ISTS 061 Astro 1968
ISTS 073 Astro 1969	Johnston Island 1961	Kandawala
Kerguelen Island 1949	Kertau 1948	Kusaie Astro 1951
L. C. 5 Astro 1961	Leigon	Liberia 1964
Luzon	M'Poraloko	Mahe 1971
Massawa	Merchich	Midway Astro 1961
Minna	Montserrat Island Astro 1958	Nahrwan Masirah Is. Oman
Nahrwan United Arab Emirates	Nahrwan Saudi Arabia	Naparima, BWI
North American 1927	North American 1983	North Sahara 1959
Observatorio Meteorolog. 1939	Old Egyptian 1907	Old Hawaiian
Oman	Ord. Survey Great Britain 1936	Pico de las Nieves
Pitcairn Astro 1967	Point 58	Pointe Noire 1948
Porto Santo 1936	Provis. South American 1956	Provis. South Chilean 1963
Puerto Rico	Pulkovo 1942	Qatar National
Qornoq	Reunion	Rome 1940
S-42 (Pulkovo 1942)	Santo (DOS) 1965	Sao Braz
Sapper Hill 1943	Schwarzeck	Selvagem Grande 1938
Sierra Leone 1960	S-JTSK	South American 1969
South Asia	Tananarive Observatory 1925	Timbalai 1948
Tokyo	Tristan Astro 1968	Viti Levu 1916
Voirol 1874	Voirol 1960	Wake Island Astro 1952
Wake-Eniwetok 1960	WGS 84	Yacare
Zanderij		

Appendix B - Troubleshooting

This troubleshooting guide is written with the assumption that the user has read and understood the relevant sections in this manual.

It is possible in many cases to solve difficulties without having to send the display unit back to the manufacturer for repair. Please follow this troubleshooting section before contacting the nearest Northstar dealer.

There are no user serviceable parts. Specialized methods and testing equipment are required

to ensure that the display unit is reassembled correctly and is waterproof. Users who service the product themselves will void the warranty.

Repairs to the product may only be carried out by a service centre approved by Northstar. If the product must be sent into a service centre for repair, it is essential to send in the transducer(s) at the same time.

More information can be found on our Website: www.Northstarnav.com.

B-1 General Problems

1-1 The Explorer 538/538i won't turn on:

- a The Explorer 538/538i is designed to operate on a 12 volt battery system, where the voltage may vary from 10 to 16 volts. If an excessive voltage is supplied, a fuse will be tripped, turning the display unit off. Check the fuse.
- b Check that the power cable connector at the back of the display unit is securely plugged in and the collar is locked in place. The collar must be secure for watertight connection.
- c Measure the battery voltage while the battery is under load - turn on some lights, radio or other electrical equipment connected to the battery. If the voltage is less than 10 volts:
 - the battery terminals or wiring on the terminals may be corroded.
 - the battery may not be charging correctly or may need replacing.
- d Inspect the power cable from end to end for damage such as cuts, breaks, squashed or trapped sections.
- e Ensure that the red wire is connected to the positive battery terminal and the black wire to the negative battery terminal. If wired for the Auto Power option, ensure the yellow wire is connected to the ignition circuit. Also check the boat's main switch circuit (see section 15-4).

- f Check for corrosion on the power cable connector and clean or replace if required.
- g Check fuses that are placed in line with the power cable. A fuse can be blown despite appearing to be good or the fuse may be corroded. Test the fuse or replace it with a fuse known to be good.

1-2 The Explorer 538/538i won't turn off:

The Explorer 538/538i may have been wired for Auto power. In this case, the Explorer 538/538i cannot be turned off while the ignition power is on (see section 2-3).

1-3 If the Explorer 538/538i beeps when turned on but nothing is displayed:

The Explorer 538/538i may be operating, but the backlight settings may have been set too low (see section 2-4).

1-4 The wrong language is displayed:

See section 14-1.

B-2 GPS navigation problems

2-1 No GPS fix or long time to get fix at startup:

- May occur occasionally if the antenna does not have a clear view of the sky. The satellite positions are constantly changing.
- Antenna cable not connected to display unit.
- Restart the GPS (see section 14-3).

2-2 Explorer GPS position different from true position by more than 10 m (33 ft):

- Explorer in simulate mode. Turn simulate mode off (see section 14-12).
- The normal error in GPS position will exceed 10 m (33 ft) for about 5% of the time.
- Under special circumstances the US Department of Defence may introduce a deliberate and changing error in the GPS positions of up to 300 m (1000 ft).

2-3 Explorer position different from same position on local charts:

- Explorer in simulate mode. Turn simulate mode off (see section 14-12).
- Incorrect chart datum. Select the correct chart datum (see section 14-2).
- Map shift has been applied wrongly. Clear map shift, then reapply if necessary (see section 14-2).

2-4 Can not see boat on chart:

- Press **ESC** to switch to centre on boat mode (see section 3-2-1).

2-5 The time or date on satellite display is wrong or off:

- No GPS fix.
- In simulate mode. Turn simulate mode off (see section 14-12).
- Local time offset is wrong (see section 14-11). The Local Time Offset must be changed when daylight saving time starts or ends.

2-6 Autopilot not responding to Explorer; no NMEA output:

- NMEA output disabled or the required NMEA sentences are not turned on. Check NMEA settings (see section 17-10).
- Check that the instrument is connected correctly.

2-7 No DGPS fix or loss of DGPS fix:

- To receive a DGPS fix, WAAS/EGNOS must be enabled or an optional DGPS antenna fitted (see section 7).
- With WAAS/EGNOS: Boat out of coverage area (see section 7).
- With WAAS: GPS antenna does not have a clear view of the horizon towards the equator.
- With beacon DGPS: boat out of range of a DGPS beacon.

B-3 Fuel consumption problems

Note: For the Explorer 538/538i to measure fuel consumption, the optional fuel flow kit must be fitted.

3-1 Fuel used or remaining seem inaccurate:

Explorer is not wired for auto power (see section 15-4).

- b In rough seas, fuel may surge back and forth through the fuel transducer, resulting in incorrect readings. Try installing a one-way valve between the fuel transducer and the fuel tank.
- c The **Set remaining** fuel value must be reset after every refuelling (see section 10-1).
- d The fuel tank may not refill to the same capacity each time due to air pockets. This is particularly noticeable with underfloor tanks.
- e Fuel transducers wear out over time and should be replaced after every 5000 litres of fuel.

3-2 Flow indicates no fuel or low fuel:

- a Check that the number of engines is set to 1 (see section 14-4).
- b Check that the fuel cable connectors are securely plugged in and the collar is locked in place. The collar must be locked in place to give a watertight connection.
- c A fuel transducer may be clogged. If so, remove the transducer from the fuel line and gently blow through it in the opposite direction to the fuel flow.

A fuel filter between the fuel transducer and the fuel tank must be installed as per the fuel installation guide. Failure to do so will void the warranty.

- d Inspect the fuel cable from end to end for damage such as cuts, breaks, trapped or squashed sections.
- e Check that the fuel filter is clean.

3-3 A twin engine installation shows only one flow rate:

- a Check that the number of engines is set to 2 (see section 14-4).

3-4 Erratic Fuel Flow readings:

- a The fuel flow transducer may have been mounted too close to the fuel pump or may be subject to excessive vibration. Refer to the installation instructions supplied with the fuel transducer.
- b Check for leaks in the fuel line or in the fuel pickup in the tank.
- c The **Flow filter** value is not suitable for the engine. Check that the value is not set to zero, then try increasing the value until a steady flow rate is shown (see section 14-4).

3-5 There is no reading for fuel economy:

- a The boat must be travelling through the water to generate an **Economy** reading.
- b Check that the paddlewheel on the transducer is spinning freely and that the two magnets in the paddlewheel are still in place.

Appendix C - Glossary and navigation data

Glossary

Attention Area - An important area on a chart, such as a restricted anchorage or a shallow area (see section 14-2).

Bathymetric line - A depth contour line on the chart.

Chart card - A plug-in card that stores chart data for a region (see section 1-3).

C-MAP™ chart card - See Chart card.

C-MAP™ user card - See User card.

Cursor - A  symbol on the display (see section 3-2).

DGPS - Differential Global Positioning System. A navigation tool based on GPS with some errors corrected (see section 7).

Goto - A simple way of navigating straight to a waypoint or to the cursor position (see section 3-1).

GPS - Global Positioning System. A satellite-based navigation tool (see section 7).

Leg - The straight segments of a route between waypoints. A route with four waypoints has three legs.

MOB - Man overboard.

MOB function - Starts navigating back to the place where someone fell overboard (see section 2-5).

NavBus - A way of connecting Northstar instruments together to share data (see section 15-8).

NMEA - National Marine Electronics Association.

NMEA 0183 - A standard for interfacing marine electronic devices (see section 15-9).

Route: Two or more waypoints linked in sequence to form a course for the boat (see section 6).

User card - A plug-in card that stores waypoints, routes and tracks (see section 1-2).

UTC - Universal Time Coordinated or Coordinated Universal Time, which is a standard world time, formerly called Greenwich Mean Time (GMT).

Waypoint - A position that you can set on the Explorer chart, for example a fishing spot or a point on a route (see section 5).

Navigation data

The boat is sailing from the start to the destination and has moved off the plotted course from the start to the destination.

BRG Bearing to Destination: Bearing to the destination from the boat.

⊕BRG Bearing to cursor: Bearing to cursor from boat (cursor mode, see section 3-2)

CDI Course Deviation Indicator: When the boat is navigating to a point, the chart and highway displays show a parallel line on either side of the plotted course. These two lines are called the Course Deviation Indicator (CDI) lines. The distance from the plotted course to a CDI line is the CDI scale.

Set the CDI scale (see section 14-2) to the maximum distance that the boat should deviate from the plotted course. The chart and highway displays show the CDI lines, which are like a highway over the water where the boat will move. The displays show how far the boat has deviated from the plotted course and if the boat is approaching a CDI line. If the XTE alarm is enabled (see section 14-7) an alarm will sound if the boat reaches a CDI line.

COG Course Over Ground: Direction in which the boat is moving over the ground.

CTS Course To Steer: Optimum course to steer to return to the plotted course.

DTG Distance To Go: Distance from the boat to the destination.

ETA Expected Time of Arrival: At the destination, assuming that SOG and COG remain constant.

⊕RNG Range to cursor: Distance from boat to cursor (cursor mode, see section 3-2)

SOG Speed Over Ground: Current boat speed over the ground. This is not necessarily the same as the boat speed through the water nor the speed at which it is approaching the destination.

STR Steering: The difference between COG and CTS.

TTG Time To Go: The estimated time to reach the destination.

XTE Cross Track Error: The distance from the boat to the nearest point of the plotted course. XTE may have a letter: R means steer to the right to return to the plotted course, L means steer to the left.

VMG Velocity Made Good: The speed at which the boat is approaching the destination.

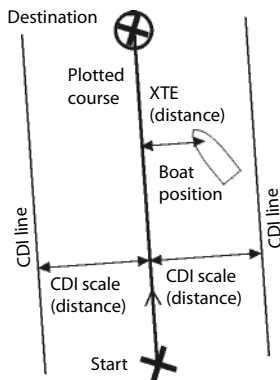
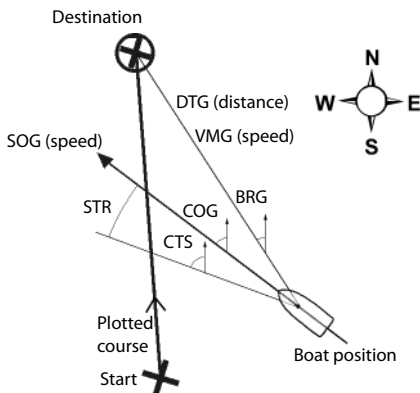

AMERICAS

30 Sudbury Road,
Acton, MA 01720, USA
Ph: +1 978.897.6600
Ph: +1 800.628.4487
Fax: +1 978.897.7241
sales@bntmarine.com

EUROPE

Unit 2, Ocean Quay,
Belvidere Rd, Southampton,
SO14 5QY, ENGLAND
Ph: +44 2380 339922
Fax: +44 2380 330345
northstaruk@northstarnav.com

AUSTRALIA

PO Box 479,
Gladesville, NSW 2111,
AUSTRALIA
Ph: +61 2 9879 9060
Fax: +61 2 9879 9009
northstaraus@northstarnav.com

NEW ZEALAND

PO Box 68 155,
Newton, Auckland
Auckland, NEW ZEALAND
Ph: +64 9 481 0500
Fax: +64 9 481 0590
northstarnz@northstarnav.com

www.northstarnav.com

NORTHSTAR 



Made in New Zealand
MN000594A-G